

# MEDIUM PRESSURE DUCT

## Installation and owner's manual



# Preface

Dear users,

Thank you for purchasing and using our product. Please read this manual carefully before you install, use, maintain or troubleshoot this product so that you can familiarize yourself with the product and use it correctly.

For ODUs or other IDUs, please refer to the applicable installation & owner's manuals provided with them.

For detailed operation of auxiliary control devices, such as wired, remote and centralized controllers, please refer to their instructions.

To ensure the correct installation and operation of the product, the following instructions are provided:

- ④ To ensure the correct and safe operation of the product, please strictly follow the requirements listed in this manual.
- ④ All figures and contents in this manual are for reference only. Due to continuing product improvement, the specifications are subject to change without notice.
- ④ Regular cleaning and maintenance of the product are required for intended performance and long service life. Each year before using the air conditioner, please contact your local dealer, and we will assign professionals to provide paid services of cleaning, maintenance, and inspection.
- ④ Please retain this manual for future reference.

# Contents

## **Safety Warning** 1

---

Warning Signs / 1	Safety Precautions / 2
Electric Safety Requirements / 3	Appendix / 3

## **Operation** 7

---

Operation Precautions / 7	Optimum Operation / 8
Symptoms That Are Not Faults / 10	Display Box (Optional) / 12

## **Installation** 13

---

Installation Precautions / 13	Installation Materials / 19
Preparations Before Installation / 21	IDU Installation / 23
Refrigerant Connecting Piping Installation / 26	Drainage Pipe Installation / 32
Air Duct Installation / 36	Electrical Connection / 38
Application Control / 54	Test Run / 65

## **Cleaning, Maintenance and After-Sales Service** 67





---

Safety Warning / 67	Cleaning and Maintenance / 67
Maintenance of Conventional Parts / 70	

Please thoroughly read and ensure that you fully understand the safety precautions (including the signs and symbols) in this manual, and follow relevant instructions during use to prevent damage to health or property.

# Safety Warning

Explanation of symbols displayed on the unit

	WARNING	This symbol shows that this appliance used a flammable refrigerant. If the refrigerant is leaked and exposed to an external ignition source, there is a risk of fire.
	CAUTION	This symbol shows that the operation manual should be read carefully.
	CAUTION	This symbol shows that a service personnel should be handling this equipment with reference to the installation manual.
	CAUTION	This symbol shows that information is available such as the operating manual or installation manual.



**Caution: Risk of fire**

(for IEC 60335-2-40: 2018 only)



**Caution: Risk of fire**

(for IEC/EN 60335-2-40  
except IEC 60335-2-40: 2018)

## [ Note ]

The symbols above is for R32 refrigerant system.

# 1 Warning Signs

Different marks are used to indicate the levels of hazard severity. Please follow the instructions and ensure safe operation.

## [ Danger ]

Failure to observe the warning will result in severe personal injury or death.

## [ Warning ]

Failure to observe the warning could result in severe personal injury or death, property damage, or electrical or fire hazards.

## [ Caution ]

Failure to observe the warning could result in minor personal injury, product or property damage, or other unsafe situations.

## [ Note ]

Useful operation and maintenance information.

## ⚠ Warning contents



Ensure Proper Grounding



Professional Only

## ⊘ Prohibition signs



No Flammable Materials



No Strong Current



No Open Fire



No Acid or Alkali Materials

# 2 Safety Precautions

## ⊘ [ Danger ]

During thunderstorms, disconnect the main power switch. Otherwise, lightning may damage the unit.

In the event of refrigerant leakage, smoking and open flames are prohibited. Disconnect the main power switch immediately, open windows to allow ventilation, keep away from the leakage point, and contact your local dealer or technical support to request a professional repair.

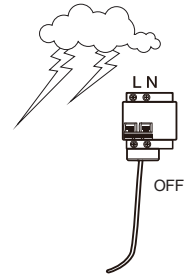

## ⚠ [ Warning ]

Air conditioner installation must comply with local standards and electrical codes, and relevant instructions in this manual.

Do not use any liquid cleanser, liquefied cleanser, or corrosive cleanser to wipe this unit or spray water or other liquids on the unit. Otherwise, the plastic parts of the unit will become damaged and an electrical shock may occur. Disconnect the main power switch before cleaning and maintenance to avoid accidents.

Ask a professional to remove and reinstall the air conditioner.

Ask a professional for maintenance and repair assistance.

This air conditioner is classified as an "appliance which is not accessible to the general public".

The IDU shall be placed at a height not accessible to children, at least 2.5m above the ground.

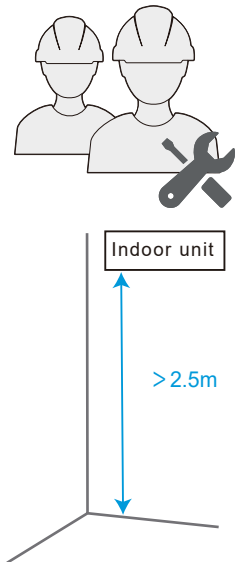

## 👤 [ Caution ]

This appliance can be used by children aged from 8 years and above and persons with reduced physical, sensory or mental capabilities or lack of experience and knowledge if they have been given supervision or instruction concerning use of the appliance in a safe way and understand the hazards involved.

Children shall not play with the appliance.

Cleaning and user maintenance shall not be made by children without supervision.

This appliance is intended to be used by expert or trained users in shops, in light industry and on farms, or for commercial use by lay persons.

When the product is used for commercial application. This appliance is intended to be used by expert or trained users in shops, in light industry and on farms, or for commercial use by lay persons, the sound pressure level is below 70 dB(A).

# 3 Electric Safety Requirements

## [ Warning ]

The air conditioner shall be installed according to the local wiring specifications.

Wiring work must be completed by qualified electricians.

All wiring work must comply with electrical safety specifications.

The air conditioner must be well grounded. Specifically, the main switch of the air conditioner must have a reliable grounding cable.

Before contacting wiring devices, cut off all the power supplies.

The user **MAY NOT** disassemble or repair the air conditioner. Doing so can be dangerous. In the event of a fault, immediately cut off the power and contact your local dealer or technical support.

A separate power supply that meets the rated parameter values must be provided for the air conditioner.

The fixed wiring to which the air conditioner is connected must be equipped with a power cut-off device that meets the wiring requirements.

To avoid danger, a damaged power cable must be replaced by professionals from the maintenance department or a similar department of the manufacturer.

The air conditioner's circuit board (PCB) is designed with a fuse to provide overcurrent protection.

The specifications of the fuse are printed on the circuit board.

*NOTE: For the units with R32 refrigerant, only the blast-proof ceramic fuse can be used.*

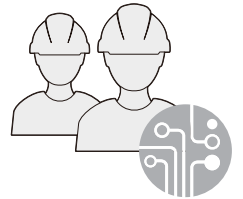
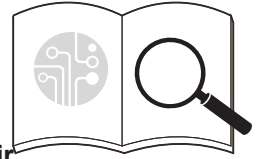

## [ Caution ]

Always ground the main power switch.

Do not use a damaged power cable and replace it if it is damaged.

When the air conditioner is used for the first time or is in a power-off state for a long time, it needs to be connected to the power supply and warmed up for at least 12 hours before use.

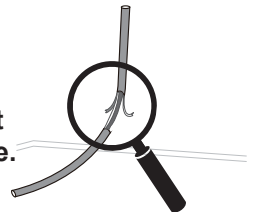

# 4 Appendix

## [ Warning ]

The following applies to r32 refrigerant systems.

Prior to beginning work on systems containing flammable refrigerants, safety checks are necessary to ensure that the risk of ignition is minimized.

For repair to the refrigerating system, the following precautions shall be complied with prior to conducting work on the system.

Work shall be undertaken under a controlled procedure so as to minimise the risk of a flammable gas or vapour being present while the work is being performed.

All maintenance staff and others working in the local area shall be instructed on the nature of work being carried out. Work in confined spaces shall be avoided. The area around the workspace shall be sectioned off. Ensure that the conditions within the area have been made safe by control of flammable material.

The area shall be checked with an appropriate refrigerant detector prior to and during work, to ensure the technician is aware of potentially flammable atmospheres.

The following applies to r32 refrigerant systems.

Prior to beginning work on systems containing flammable refrigerants, safety checks are necessary to ensure that the risk of ignition is minimized.

For repair to the refrigerating system, the following precautions shall be complied with prior to conducting work on the system.

Work shall be undertaken under a controlled procedure so as to minimise the risk of a flammable gas or vapour being present while the work is being performed.

All maintenance staff and others working in the local area shall be instructed on the nature of work being carried out. Work in confined spaces shall be avoided. The area around the workspace shall be sectioned off. Ensure that the conditions within the area have been made safe by control of flammable material.

The area shall be checked with an appropriate refrigerant detector prior to and during work, to ensure the technician is aware of potentially flammable atmospheres.

Ensure that the leak detection equipment being used is suitable for use with flammable refrigerants, i.e. non-sparking, adequately sealed or intrinsically safe.

If any hot work is to be conducted on the refrigeration equipment or any associated parts, appropriate fire extinguishing equipment shall be available to hand. Have a dry powder or CO2 fire extinguisher adjacent to the charging area.

No person carrying out work in relation to a refrigeration system which involves exposing any pipe work that contains or has contained flammable refrigerant shall use any sources of ignition in such a manner that it may lead to the risk of fire or explosion.

All possible ignition sources, including cigarette smoking, should be kept sufficiently far away from the site of installation, repairing, removing and disposal, during which flammable refrigerant can possibly be released to the surrounding space.

Prior to work taking place, the area around the equipment is to be surveyed to make sure that there are no flammable hazards or ignition risks. "No Smoking" signs shall be displayed.

Ensure that the area is in the open or that it is adequately ventilated before breaking into the system or conducting any hot work. A degree of ventilation shall continue during the period

that the work is carried out. The ventilation should safely disperse any released refrigerant and preferably expel it externally into the atmosphere.

Where electrical components are being changed, they shall be fit for the purpose and to the correct specification. At all times the manufacturer's maintenance and service guidelines shall be followed. If in doubt consult the manufacturer's technical department for assistance.

**The following checks shall be applied to installations using flammable refrigerants:**

- the charge size is in accordance with the room size within which the refrigerant containing parts are installed;
- the ventilation machinery and outlets are operating adequately and are not obstructed;
- if an indirect refrigerating circuit is being used, the secondary circuit shall be checked for the presence of refrigerant;
- marking to the equipment continues to be visible and legible. Markings and signs that are illegible shall be corrected;
- refrigeration pipe or components are installed in a position where they are unlikely to be exposed to any substance which may corrode refrigerant containing components, unless the components are constructed of materials which are inherently resistant to being corroded or are suitably protected against being so corroded.

**Repair and maintenance to electrical components shall include initial safety checks and component inspection procedures.**

If a fault exists that could compromise safety, then no electrical supply shall be connected to the circuit until it is satisfactorily dealt with. If the fault cannot be corrected immediately but it is necessary to continue operation, an adequate temporary solution shall be used. This shall be reported to the owner of the equipment so all parties are advised.

**Initial safety checks shall include:**

- that capacitors are discharged: this shall be done in a safe manner to avoid possibility of sparking;
- that no live electrical components and wiring are exposed while charging, recovering or purging the system;
- that there is continuity of earth bonding.

During repairs to sealed components, all electrical supplies shall be disconnected from the equipment being worked upon prior to any removal of sealed covers, etc. If it is absolutely necessary to have an electrical supply to equipment during servicing, then a permanently operating form of leak detection shall be located at the most critical point to warn of a potentially hazardous situation.

Particular attention shall be paid to the following to ensure that by working on electrical components, the casing is not altered in such a way that the level of protection is affected. This shall include damage to cables, excessive number of connections, terminals not made to original specification, damage to seals, incorrect fitting of glands,

etc.

Ensure that seals or sealing materials have not degraded such that they no longer serve the purpose of preventing the ingress of flammable atmospheres.

Replacement parts shall be in accordance with the manufacturer's specifications.

Do not apply any permanent inductive or capacitance loads to the circuit without ensuring that this will not exceed the permissible voltage and current permitted for the equipment in use.

Intrinsically safe components are the only types that can be worked on while live in the presence of a flammable atmosphere. The test apparatus shall be at the correct rating.

Replace components only with parts specified by the manufacturer. Other parts may result in the ignition of refrigerant in the atmosphere from a leak.

Check that cabling will not be subject to wear, corrosion, excessive pressure, vibration, sharp edges or any other adverse environmental effects. The check shall also take into account the effects of ageing or continual vibration from sources such as compressors or fans.

When breaking into the refrigerant circuit to make repairs – or for any other purpose – conventional procedures shall be used. However, it is important that best practice is followed.

Since flammability is a consideration. The following procedure shall be adhered to:

- remove refrigerant;
- purge the circuit with inert gas;
- evacuate;
- purge again with inert gas;
- open the circuit by cutting or brazing.

The refrigerant charge shall be recovered into the correct recovery cylinders. The system shall be "flushed" with OFN to render the unit safe. This process may need to be repeated several times. Compressed air or oxygen shall not be used for this task.

Flushing shall be achieved by breaking the vacuum in the system with OFN and continuing to fill until the working pressure is achieved, then venting to atmosphere, and finally pulling down to a vacuum.

This process shall be repeated until no refrigerant is within the system. When the final OFN charge is used, the system shall be vented down to atmospheric pressure to enable work to take place.

This operation is absolutely vital if brazing operations on the pipe-work are to take place.

Ensure that the outlet for the vacuum pump is not close to any ignition sources and there is ventilation available.

Ensure that contamination of different refrigerants does not occur when using charging equipment. Hoses or lines shall be as short as possible to minimise the amount of refrigerant contained in them.

Prior to recharging the system it shall be pressure tested with OFN.

#### **DD.12 Decommissioning:**

Before carrying out this procedure, it is essential that the technician is completely familiar with the equipment and all its detail. It is recommended good practice that all refrigerants are recovered safely. Prior to the task being carried out, an oil and refrigerant sample shall be taken in case analysis is required prior to re-use of reclaimed refrigerant. It is essential that electrical power is available before the task is commenced.

- a) Become familiar with the equipment and its operation.
- b) Isolate system electrically.
- c) Before attempting the procedure ensure that:
  - *mechanical handling equipment is available, if required, for handling refrigerant cylinders;*
  - *all personal protective equipment is available and being used correctly;*
  - *the recovery process is supervised at all times by a competent person;*
  - *recovery equipment and cylinders conform to the appropriate standards.*
- d) Pump down refrigerant system, if possible.
- e) If a vacuum is not possible, make a manifold so that refrigerant can be removed from various parts of the system.
- f) Make sure that cylinder is situated on the scales before recovery takes place.
- g) Start the recovery machine and operate in accordance with manufacturer's instructions.
- h) Do not overfill cylinders. (No more than 80 % volume liquid charge).
- i) Do not exceed the maximum working pressure of the cylinder, even temporarily.
- j) When the cylinders have been filled correctly and the process completed, make sure that the cylinders and the equipment are removed from site promptly and all isolation valves on the equipment are closed off.
- k) Recovered refrigerant shall not be charged into another refrigeration system unless it has been cleaned and checked.

Equipment shall be labelled stating that it has been de-commissioned and emptied of refrigerant. The label shall be dated and signed. Ensure that there are labels on the equipment stating the equipment contains flammable refrigerant.



**When removing refrigerant from a system, either for servicing or decommissioning, it is recommended good practice that all refrigerants are removed safely.**

**When transferring refrigerant into cylinders, ensure that only appropriate refrigerant recovery cylinders are employed. Ensure that the correct number of cylinders for holding the total system charge are available. All cylinders to be used are designated for the recovered refrigerant and labelled for that refrigerant (i.e. special cylinders for the recovery of refrigerant). Cylinders shall be complete with pressure relief valve and associated shut-off valves in good working order. Empty recovery cylinders are evacuated and, if possible, cooled before recovery occurs.**

**The recovery equipment shall be in good working order with a set of instructions concerning the equipment that is at hand and shall be suitable for the recovery of flammable refrigerants. In addition, a set of calibrated weighing scales shall be available and in good working order. Hoses shall be complete with leak-free disconnect couplings and in good condition. Before using the recovery machine, check that it is in satisfactory working order, has been properly maintained and that any associated electrical components are sealed to prevent ignition in the event of a refrigerant release. Consult manufacturer if in doubt.**

**The recovered refrigerant shall be returned to the refrigerant supplier in the correct recovery cylinder, and the**

# Operation

## 1 Operation Precautions

### [ Warning ]

If the unit will be not used for a long time, disconnect the main power switch. Otherwise, an accident may occur.

The installation height of the air conditioner shall be at least 2.5m above the ground to avoid the following risks:

1. *Touching of moving or live parts, such as fans, motors, or louvers, by a non professional. Running parts may cause harm to you or transmission assemblies may become damaged.*
2. *Getting too close to the air conditioner may reduce the level of comfort.*

When the product is used with a burning appliance, the room must be ventilated regularly. Otherwise, it may cause an insufficient oxygen supply.

Do not let children play with the air conditioner. Otherwise, an accident may occur.

Do not expose the IDUs or controller to moisture or water as this may cause short circuiting or fire.

Do not place any appliance that uses an open flame in the direct air supply of the air conditioner as it could interfere with the combustion of the appliance.

Do not use or store flammable gases or liquids such as natural gas, hair spray, paint or gasoline near the air conditioner. Otherwise, a fire may occur.

To avoid causing harm, do not place animals or plants directly in front of the air conditioner's air supply.

In the event of abnormal conditions such as abnormal noise, smell, smoke, temperature rise, and electric leakage, please cut off the power immediately, and then contact your local dealer or air conditioner customer service center. Do not repair the air conditioner by yourself.

Do not place flammable sprayers near the air conditioner or spray it directly at the air conditioner. Otherwise, a fire may occur.

Do not place a container of water on the air conditioner. If immersed in water, the air conditioner's electrical insulation will weaken, resulting in electrical shock.

After long-term use, confirm whether the installation platform has become worn. If it is worn, the unit could fall, causing injury.

Do not operate the switch with wet hands, as this may result in electric shock.

When servicing the air conditioner, be sure to turn off the air conditioner and cut off the power supply. Otherwise, the high-speed operation of the internal fan will cause injury.

The air conditioner cannot be used to preserve food, animals and plants, precision instruments and works of art, etc.; otherwise, quality degradation could occur.

Do not use fuses like iron or copper wire other than those with the specified capacity. Otherwise, a malfunction or fire may occur. The power supply must use the special circuit of the air conditioner at the rated voltage.

Do not place valuables under the air conditioner. Air conditioner condensation problems may damage the valuables.

When the air conditioner needs to be moved and re-installed, please entrust the local dealer or a professional technician to operate it.

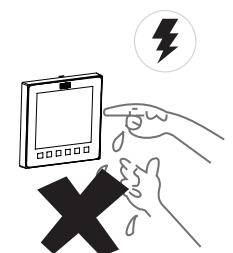
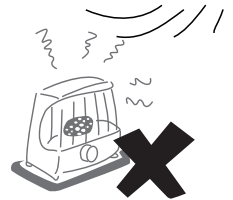

**Disposal:** Do not dispose of this product as unsorted municipal waste. Collection of such waste separately for special treatment is necessary.

*Do not dispose of electrical appliances as unsorted municipal waste, use separate collection facilities. Contact your local government for information regarding the collection systems available.*

*If electrical appliances are disposed of in landfills or dumps, hazardous substances can leak into the groundwater and get into the food chain, damaging your health and well-being.*



## [ Caution ]

To use the unit normally, please follow the "Operation" section in this manual. Otherwise, the internal protection may be triggered, the unit may begin to drip, or the unit's cooling and heating effects may be impacted.

The room temperature should be set properly, especially when there are elderly, children, or patients in the room.

Lightning or the starting and stopping of large electrical equipment in nearby factories may cause misoperation of the air conditioner. Please turn off the main power switch for a few seconds, and then restart the air conditioner.

To avoid accidental resetting of the thermal circuit breaker, the air conditioner cannot be powered by an external switching device such as a timer or connected to a circuit that is turned on and off by a common component timer.

Check whether the air filter is installed properly. Confirm that the inlet and outlet ports of the IDU/ODU are not blocked.

If the air conditioner will not be used for a long time, please clean the air filter before you start the air conditioner. Otherwise, dust and mold on the filter could contaminate the air or produce an unpleasant odor. For more details, please refer to the section "Cleaning and Maintenance".

When using the air conditioner for the first time or replacing the filter, complete the following settings on the controller:

1. Reset the initial static pressure on the controller or perform a trial run on the ODU (performed by the installer), and set the current state as a reference state for the unit to determine the filter state. (For details, see the Application Control section)
2. Set the difference between the initial resistance and the final resistance of the filter. (For details, see the wired controller manual.)

If the above operations are not performed, then the unit may not detect the state of the filter accurately.

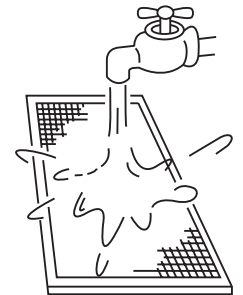
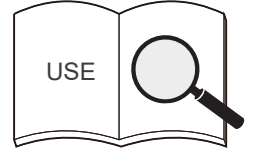

## 2 Optimum Operation

As cold air sinks and hot air rises, adjust the direction of louvers respectively in cooling and heating modes to ensure good cooling and heating effects.

### In Cooling Mode

To improve the cooling effect in the entire room, adjust the louvers of the air outlet grille horizontally.

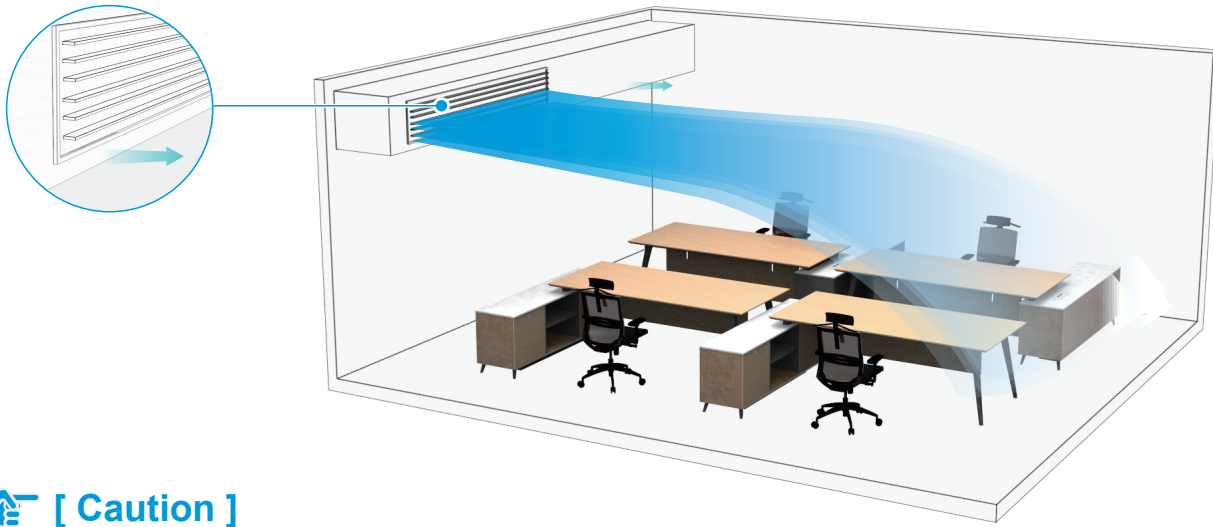

**[ Caution ]**

Cooling in the downward outlet state may cause condensation on the air outlet and guide louver surface.

## In Heating Mode

To improve the heating effect in the lower parts of a room, adjust the louvers of air outlet grille downwards.

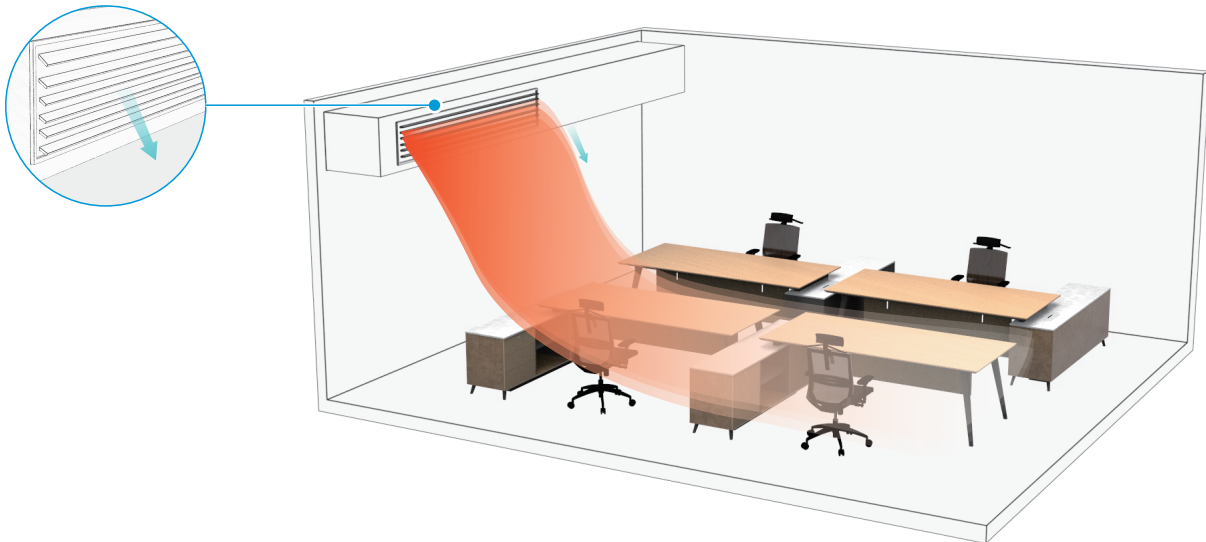

## Operating Range

To maintain good performance, operate the air conditioner under the following temperature conditions:

Cooling	Indoor temperature	16~32°C
	Indoor humidity	≤80% (When the humidity exceeds 80%, long-time operation of the IDU may cause dew condensation on the surface of the IDU or generate mist-like cold air from the air outlet.)
Heating	Indoor temperature	15~30°C

**[ Caution ]**

The IDU operates stably within the temperature range given in the table above. If it exceeds this normal operating range, the IDU may stop running and display an error code.

# 3 Symptoms That Are Not Faults

## Normal Protection of the Air Conditioner

During operation, the following phenomena are normal and do not require maintenance.



When the power switch is on, if you start the system right after it is stopped, it is normal that the ODU does not operate for about four minutes as frequent compressor start/stop is not supported.



In heating mode (including heating in automatic mode), when the indoor heat exchanger does not reach a certain temperature, the indoor fan temporarily shuts off, or runs in Low mode until the heat exchanger heats up to prevent the blowing of cold air.



When the outdoor temperature is low and the humidity is high, the ODU's heat exchanger may become frosted, which may reduce the heating capacity of the air conditioner. If this occurs, the air conditioner will stop heating, enter automatic defrosting mode, and return to heating mode after defrosting has been completed.

During the defrosting, the outdoor fan stops running and the indoor fan runs using the anti-cold air protection function.

The defrosting operation time varies depending on the outdoor temperature and the degree of frosting. It generally takes 2 to 10 minutes.

During the defrosting process, the ODU may emit steam due to the rapid defrosting, which is normal.



When the IDU detects high humidity, the air conditioner will adjust the louver angle and the fan speed to prevent condensation and avoid dripping. (If a third-party panel is selected, this function is not available.)

## Normal Phenomena that Are Not Air Conditioner Faults

The following phenomena are normal during operation of the air conditioner. They can be solved according to the instructions below or do not need to be solved.

### ■ The IDU emits white mist

- ① In an environment where the indoor relative humidity is too high, when the IDU runs in cooling mode, white mist may appear due to the humidity and the temperature difference between the air inlet and outlet.
- ② When the air conditioner is switched to heating mode after defrosting, the IDU discharges the moisture generated from defrosting as steam.

### ■ The IDU blows dust

When the air conditioner has not been used for a long time or is used for the first time, the air filter should be cleaned. Otherwise, dust that has entered the IDU will be blown out.

### ■ The IDU emits odor

The IDU absorbs the odors of rooms, furniture or cigarettes, etc., and disperses the odors during operation. It is advised to have the air conditioner cleaned and maintained regularly by professional technicians.

### ■ Water drips on the air conditioner surface

When the indoor relative humidity is high, it is normal for condensation or slight water blowing to occur on the surface of the air conditioner.

---

- **"Self-cleaning" sound of icing**

During self-cleaning, there may be a slight clicking sound for about 10 minutes, indicating that the IDU is freezing, which is normal.

---

- **The air conditioner makes low noise**

- ① When the air conditioner is in "Auto", "Cool", "Dry", and "Heat" modes, it may emit a low continuous "hissing" sound, which is caused by the refrigerant flowing between the IDU and the ODU.
  - ② A "hissing" sound may be heard for a short time after the air conditioner stops operation or during "defrosting", which is caused when the refrigerant stops flowing or changes its flow.
  - ③ When the air conditioner is in Cool mode or Dry mode, a small and continuous rustling sound can be heard, which is caused by the drain pump.
  - ④ When the air conditioner starts or stops running, you may hear a squeaking sound which is produced by the expansion or shrinkage of parts or surrounding aesthetic materials due to temperature change. The sound will disappear when the air conditioner is running normally.
- 

- **Switching from cooling/heating (not available for cooling only units) mode to fan only mode**

When the IDU reaches the set temperature, the air conditioner controller automatically stops the compressor operation and switches to the fan only mode. When the room temperature rises (in cooling mode) or falls (in heating mode) to a certain level, the compressor is restarted and cooling or heating operation is resumed.

---

- **In winter, the outdoor temperature is low, and heating effects may be decreased**

- ① During the heating operation of the heat pump type air conditioner, the air conditioner absorbs heat from the outdoor air and releases it to heat the indoor air. This is the heat pump heating principle of the air conditioner.
  - ② When the heat pump runs in heating mode, the ODU blows out cold air, causing the outdoor temperature to drop. When the outdoor temperature is extremely low, the heating capability of the air conditioner drops gradually. You are advised to use other heating devices for heating.
- 

- **Mode conflict**

All IDUs in the same air conditioning system can only operate in the same mode, for example, cooling, heating or others. If IDUs are in different modes, a conflict will occur, making the system unable to start. Make sure that all the IDUs operate in the same mode.

---

- **No heating or cooling options**

For the same air conditioning system, if ODU operates in changeover mode, the main wired controller allows users to select modes supported by the IDUs, while the wired controller of a non-master IDU displays the icon of "No heating or cooling options". In this case, the mode setting is unavailable, and other IDUs operate in the same mode as the master IDU.

---

## 4 Display Box (Optional)

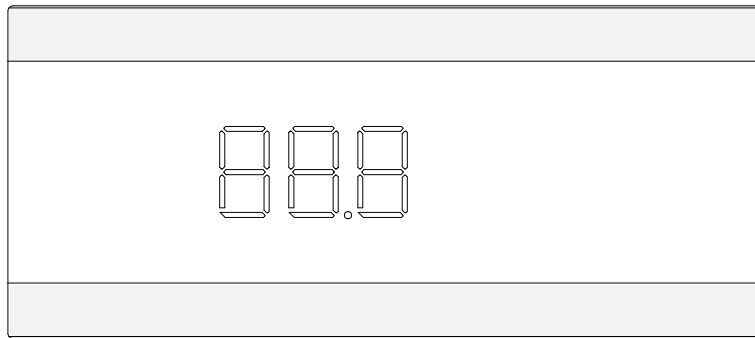
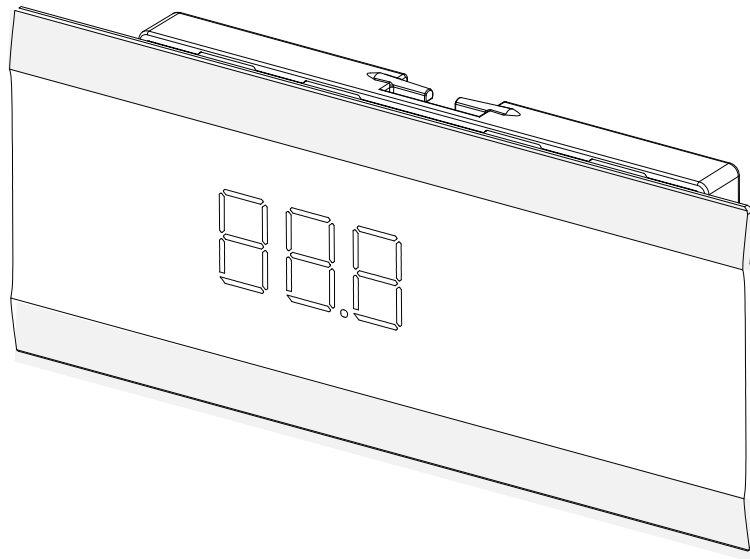

### Display functions:

- ① In Standby mode, the main interface displays “---”.
- ② When starting up in Cooling or Heating mode, the main interface displays the set temperature. In Fan mode, the main interface displays the indoor temperature. In Dry mode, the main interface displays the set temperature, and when the humidity is set, the set humidity value is displayed on the wired controller.
- ③ The light display on the main interface can be turned on or off through the light button on the remote controller.
- ④ When the system fails or runs in a special mode, the main interface displays the error code or the special mode running code. For details, see the section “Error Codes and Meanings”.

### [ Caution ]

Some display functions are available only for certain IDU and ODU models, wired controllers, and display boxes. For more information, please consult your local dealer or technical support.

# Installation

Carefully read this manual before installing the IDU.

## 1 Installation Precautions

### Qualification and Safety Regulation Requirements

#### [ Warning ]

**Please carry out the installation according to local standards.**

**Ask your local dealer or professionals to install the product.**

This unit must be installed by professional technicians with relevant specialized knowledge. Users MAY NOT install the unit themselves; otherwise, faulty operations may cause the risks of fire, electrical shock, injury, or leakage, which could harm you or others or damage the air conditioner.

**Never modify or repair the unit on your own.**

Otherwise, a fire, electric shock, injury or water leakage may occur. Get your local dealer or a professional to do so.

**Ensure that the residual current device (RCD) is installed.**

The RCD must be installed. Failure to install it may result in electric shock.

**When powering the unit, follow the regulations of the local electric company.**

Make sure that the unit is grounded reliably in accordance with laws. If the grounding is not completed correctly, it may cause electrical shock.

**When moving, disassembling or reinstalling the air conditioner, get the assistance of your local dealer or a professional.**

If installed improperly, fire, electrical shock, injury, or water leakage may occur.

**Use the optional accessories specified by our company.**

The installation of these accessories must be carried out by professionals. Improper installation may cause fire, electrical shock, water leakage and other hazards.

**Use only power cables and communication cables that meet specification requirements. Properly connect all the wiring to make sure that no external forces are acting on the terminal blocks, power cables and communication cables. Improper wiring or installation may cause a fire.**

**The air conditioner must be grounded. Check whether the earth line is securely connected or broken. Do not connect the ground line to gas cans, water piping, lightning rods or telephone earth lines.**

**The main power switch of the air conditioner should be put in a position that is out of the reach of children.**

It should not be obstructed by flammable objects such as curtains.

**Open flames are prohibited when refrigerant leaks are present.**

If the air conditioner is not cooling/heating properly, this may be caused by a refrigerant leak. If this occurs, contact your local dealer or a professional. The refrigerant in the air conditioner is safe, and usually does not leak.

If there is refrigerant leakage in the room, it is easy for a fire to occur after contact with the heating units of the heater/electric stove/stove. Please disconnect the power supply of the air conditioner, extinguish the flames of appliances that produce a flame, and open the windows and doors of the room to allow ventilation and ensure that the concentration of refrigerant leakage in the room does not exceed a critical level; keep away from the leakage point, and contact the dealer or professional personnel.

**After the refrigerant leakage is repaired, do not start the product until the maintenance personnel confirms that the leakage is well repaired.**

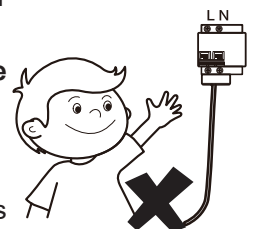
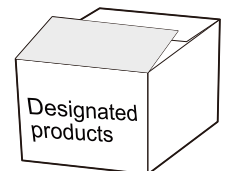
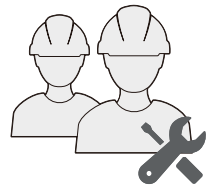



**Before and after installation, exposing the unit to water or moisture will cause electrical short circuit.**

Do not store the unit in a humid basement or expose it to rain or water.

**Make sure the installation base and lifting are robust and reliable;**

Insecure installation of the base may cause the air conditioner to fall, leading to an accident. Take into full consideration the effects of strong winds, typhoons and earthquakes, and reinforce the installation.

**Check whether the drainage pipe can drain the water smoothly.**

Improper installation of the pipeline may lead to water leakage, damaging furniture, electric appliances, and the carpet.

**After installation, check whether the refrigerant is leaking.**

**Do not install the product in a location where there is a danger of flammable gas leaks.**

In the event of leakage of combustible gas, the combustible gas surrounding the IDU may cause a fire.

**Install an air filter of 30-80 mesh/inch at the return air grille to filter dust in the air and keep the air diffuser clean and free from dirt blockage.**

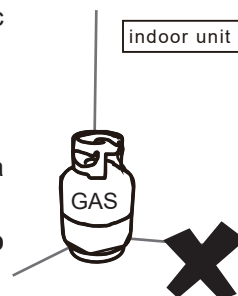

## [ Caution ]

**Keep the IDU, ODU, power cable, and connecting wires at least 1m away from the high-power radio equipment, to prevent electromagnetic interference and noise. For some electromagnetic waves, it is not enough to prevent noise even at a distance of more than 1m.**

**In a room equipped with fluorescent lamps (rectifier type or fast start type), the signal transmission distance of the remote controller (wireless) may not reach the predetermined value. Install the IDU as far away from the fluorescent lamp as possible.**

**Do not touch the fins of the heat exchanger, as this could cause injury.**

**For safety, please dispose of the packing materials properly.**

Nails and other packaging materials may cause personal injury or other risks. Tear up the plastic packaging bag and dispose of it properly to prevent children from playing with it, leading to suffocation.

**Do not cut off the power supply immediately after the IDU stops running.**

Some parts of the IDU like the valve body and water pump are still in operation. Please wait for at least 5 minutes before cutting off the power supply. Otherwise, water leakage and other faults may occur.

**If you have changed the length and direction of the air inlet/outlet panel or connecting duct, complete the following settings on the controller before you use the air conditioner again: (For details, see the Application Control section)**

Reset the initial static pressure on the controller or perform a trial run on the ODU (performed by the installer), and set the current state as a reference state for the unit to determine the filter status.

**If the above operations are not performed, then the unit may not detect the state of the filter accurately.**

**For evaporating units and condensing units, the instructions or markings shall include a wording to assure that the maximum operating pressure is considered when connecting to any condenser unit or evaporator unit.**

**For evaporating units, condensing units and condenser units, the instructions or markings shall include refrigerant charging instructions.**

**A warning to assure that partial units shall only be connected to an appliance suitable for the same refrigerant.**

**This unit is a partial unit air conditioner, complying with partial unit requirements of this International Standard, and must only be connected to other units that have been confirmed as complying to corresponding partial unit requirements of this International Standard.**

**The electrical interfaces shall be specified with purpose, voltage, current, and safety class of construction.**

**The SELV connection points, if provided, are to be clearly indicated in the instructions.**

**The connection point should be marked with the “read the instructions” symbol per ISO 7000-0790 (2004-01) and the Class III symbol according to IEC 60417-5180 (2003-02).**

## [ Note ]

**This unit is equipped with a refrigerant leak detector for safety. To be effective, the unit must be electrically powered at all times after installation, other than when servicing.**

**If any supplemental unit is employed to detect leaked refrigerant, such unit shall also apply this marking or be accompanied by such instructions.**









## Precautions for Carrying and Lifting the Air Conditioner

- ① Before carrying the air conditioner, determine the route that will be used to move it to the installation site.
- ② Do not unseal the air conditioner until it is moved to the installation site.
- ③ When unpacking and moving the air conditioner, you must hold the hanger seat and do not apply force to other parts, especially the refrigerant piping, drainage pipe and plastic accessories, so as to avoid damaging the air conditioner and causing personal injury.
- ④ Before installing the air conditioner, make sure that the refrigerant specified on the nameplate is being used. For the installation of the ODU, refer to the installation instructions in the Installation & Owner's Manual attached with the ODU.

## Forbidden Installation Sites

### [ Warning ]

Do not install or use the air conditioner in the following places:

-  A place filled with mineral oil, fumes or mist, like a kitchen.  
Plastic parts will age and the heat exchanger will become dirty, eventually causing the air conditioner performance to deteriorate or leak water.
-  A place where there are corrosive gases, such as acid or alkaline gases.  
Copper pipes and copper welds will be corroded, resulting in refrigerant leakage.
-  A place exposed to combustible gases and using volatile combustible gases such as diluent or gasoline.  
The electronics in the air conditioner may cause the surrounding gas to ignite.
-  A place where there is equipment emitting electromagnetic radiation.  
The control system will fail and the air conditioner will not function properly.
-  A place where there is a high salt content in the air like a coastal area.
-  Do not use the air conditioner in an environment where an explosion may occur.
-  In vehicles or cabin rooms.
-  Factories with major voltage fluctuations in the power supplies.
-  Other special environmental conditions.

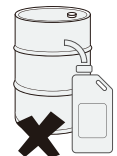





### [ Note ]

Air conditioner units of this series are designed to provide comfort. Do not use them in equipment rooms and rooms with precision instruments, food, plants, animals, or works of art.

## Recommended Installation Sites

It is recommended to install the air conditioner according to the design drawing of the HVAC engineer. The selection principle for the installation site is as follows:

-  Ensure that the airflow in and out of the IDU is reasonably organized to form an air circulation in the room.
-  Ensure IDU maintenance space.
-  The nearer the drainage pipe and copper pipe are to the ODU, the lower the pipe cost is.
-  Prevent the air conditioner from blowing directly at the human body.

- ✓ The closer the wiring is to the power cabinet, the lower the wiring cost is.
- ✓ Keep the air-conditioning return air away from direct exposure to the sun in the room.
- ✓ Be careful not to interfere with the light tank, fire pipe, gas pipe and other facilities.
- ✓ The IDU should not be lifted in the places like load-bearing beams and columns that affect the structural safety of the house.
- ✓ The wired controller and the IDU should be in the same installation space; otherwise, the sampling point setting of the wired controller needs to be changed.

Choose a site that fully complies with the following conditions and user requirements to install the air conditioning unit:

- ✓ There is enough space for installation and maintenance. (See the diagram on the right.)
- ✓ The ceiling is level, and the structure is strong enough to support the IDU. If necessary, take measures to reinforce the unit's stability.
- ✓ Airflow in/out of the machine is not obstructed, and the external air exerts minimum impact.
- ✓ It is easy to supply airflow to every corner of the room.
- ✓ It is easy to drain fluids from the connected piping and water discharge piping.
- ✓ There is no direct heat radiation.
- ✓ Avoid installation in narrow spaces or where there are more stringent noise requirements.
- ✓ Install the IDU at a place 2.5m above ground.
- ✓ Condensate water can be discharged smoothly.
- ✓ The length of the piping between the indoor and ODUs is within the permitted range. Refer to the Installation & Owner's Manual attached with the ODU.

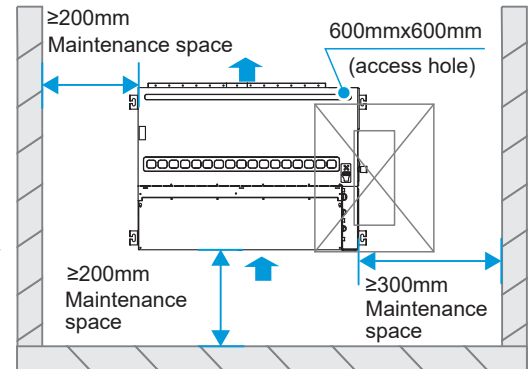

## Recommended Installation Sites



### Crowded places such as living rooms and offices

The unit is usually installed in a concealed manner, with air supplied in the side and returned at the bottom.

The air outlet must not face areas where people frequently spend time, such as sofas and coffee tables. Instead, the breeze should flow out from the side to increase comfort.



### Dining room

As the dining room is generally located next to the kitchen, which is usually filled with oily fumes, the central air conditioner can be installed on the ceiling between the dining room and the kitchen. The air outlet must not face the dining table. Otherwise, dust on the air outlet on the ceiling may be blown onto the food. Keep the return air inlet as far away from the kitchen as possible to avoid intaking oily fumes and affecting the air quality.



### Bedroom

The unit can be installed on the ceiling above the bedroom doors or near windows. The air is flexibly supplied in the side and returned at the bottom. Avoid directing streams of air towards the bed if possible.

## Part Description

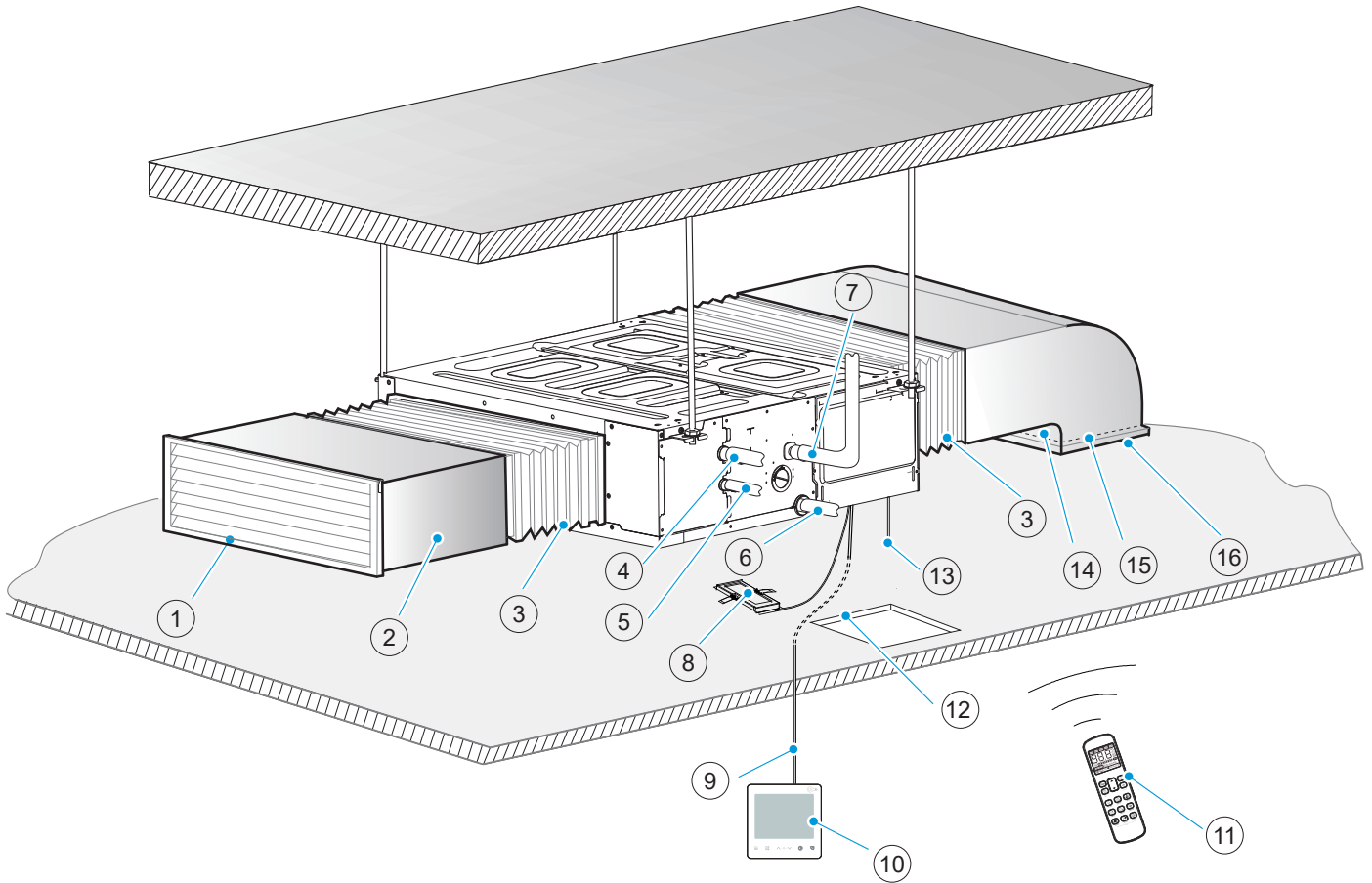

- ① \*Air outlet grille
- ④ Gas pipe
- ⑦ Drainage pipes for models with a water pump
- ⑩ Wired controller (optional)
- ⑬ \*Power cable and ground wire
- ⑯ \*Return air grille

- ② \*Air outlet pipe
- ⑤ Liquid pipe
- ⑧ Display box (optional)
- ⑪ Remote controller (optional)
- ⑭ \*Air return pipe

- ③ \*Soft flexible hose
- ⑥ Drainage pipes for models without a water pump
- ⑨ \*Connection wire
- ⑫ Access hole
- ⑮ Air filter

\* To be purchased separately on site.

### [ Note ]

All the optional accessories should be from our company.

For optional accessories such as wired controllers, please refer to the instructions of the product.

All the figures in the manual explain only the general appearance and functions of the product. The appearance and functions of the product you purchased may not be completely consistent with those listed in the figures. Please refer to the actual product.

# Product Dimensions

(Unit: mm)

External dimension, air outlet size, and size of fresh air outlet:

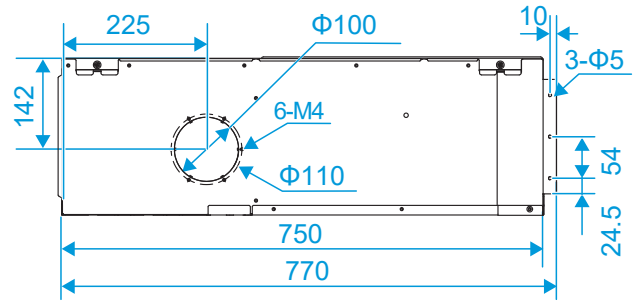
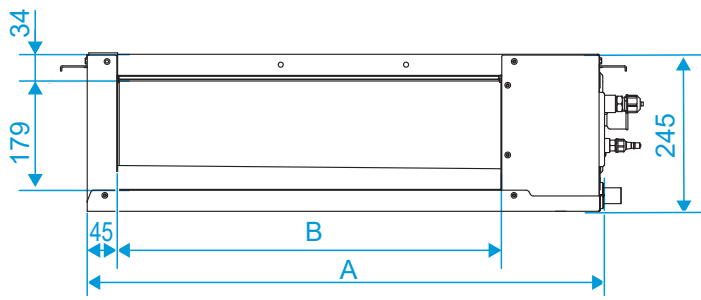

Size of return air inlet (back return air mode):

Dimension of pipe and water pipe:

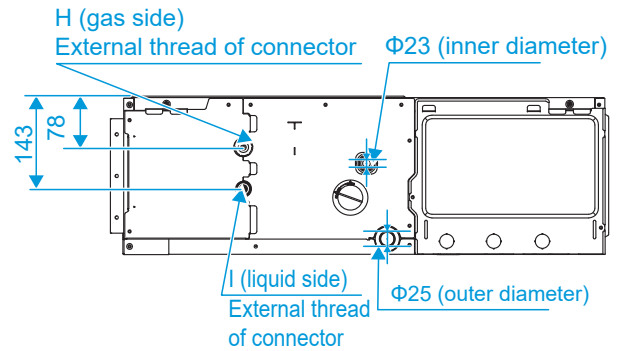
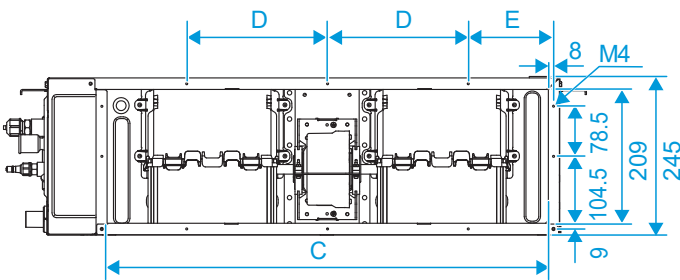

Size of return air inlet (bottom return air mode), and the distance between the lugs:

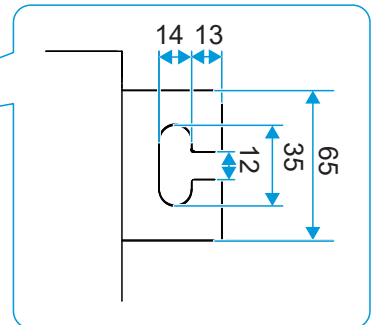
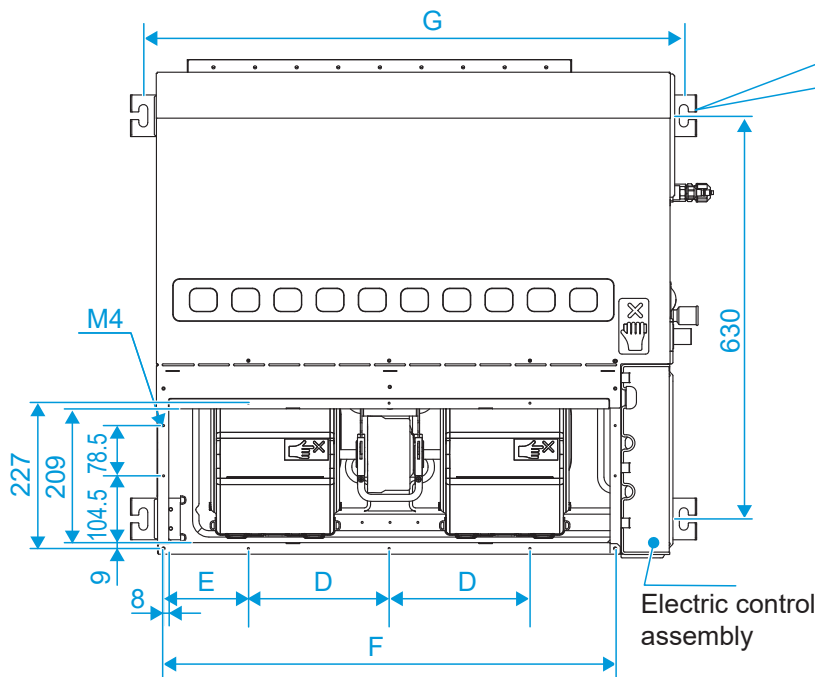

Unit power (kW)	A	B	C	D	E	F	G	H	I
kW≤4.5	600	400	490	87.5	165	506	645	3/4-16 UNF	7/16-20 UNF
4.5 < kW ≤ 5.6	800	600	690	220	134	706	845	3/4-16 UNF	7/16-20 UNF
5.6 < kW ≤ 7.1	800	600	690	220	134	706	845	7/8-14 UNF	5/8-18 UNF
7.1 < kW ≤ 11.2	1050	850	940	220	146	956	1095	7/8-14 UNF	5/8-18 UNF
11.2 < kW ≤ 16.0	1400	1200	1290	220	213	1306	1445	7/8-14 UNF	5/8-18 UNF

# 2 Installation Materials

## Accessories

### List of accessories

Installation & Owner's Manual X 1 IDU Installation Instructions (Make sure to hand it over to the user)	Brass nut X 2 For use in the installation of connecting pipe (the quantity is one for models with a process pipe)	Drainage pipe X 1 Unavailable for units with a drain pump	Cable tie X 4 To tighten the drainage hose tightly to the drainage outlet and PVC piping of the IDU.	Thermal insulation pipe X 2 Used for insulation and anti-condensation at pipe connections.
Mounting spring X 2 Mounting display box (for some models)	Air filter X 1 (For some models X 2)	Screw package X 1		

### [ Caution ]

When installing the insulation pipe on site, please cut it according to the actual needs. (Either method (a) or (b) is OK. Method (c) is incorrect. There must be no gap between the insulation pipe and copper pipe.)

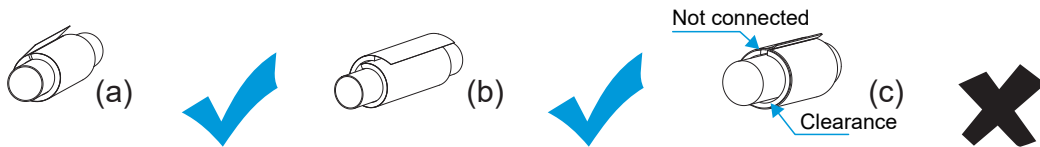

### [ Note ]

Check the accessory kit for the above items and contact your local dealer for any missing items.

Do not throw away any accessories that may be required for installation until the installation is complete.

Customers are free to choose to buy wired controllers, display boxes, remote controllers (with a seven-speed wind controller) and other optional accessories.

Air filters are divided into primary efficiency filters, medium efficiency filters, and high efficiency filters. High efficiency filters can be customized by the dealer.

Primary efficiency filter

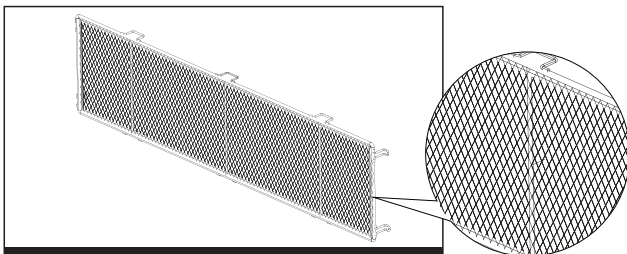

Medium efficiency filter

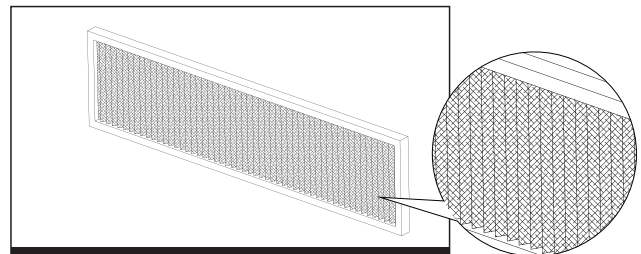

High efficiency filter

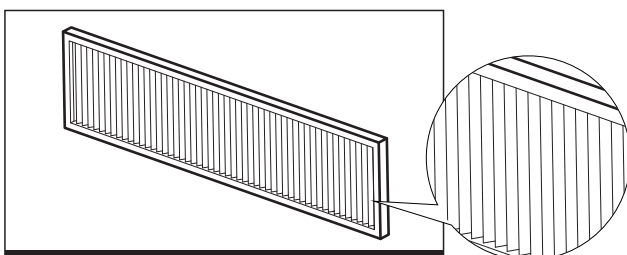

## Locally Purchased Accessories

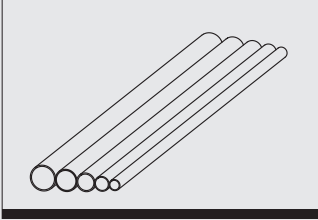
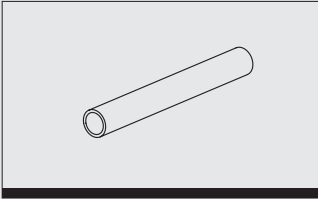
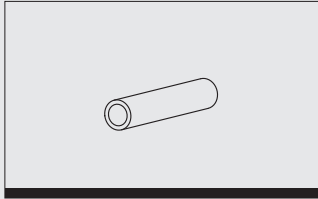
	Copper pipe (Unit: mm)		
	Capacity (kW)	Piping	Gas side
	kW≤5.6	Φ6.35×0.75	Φ12.7×0.75
	5.6 < kW≤16.0	Φ9.52×0.75	Φ15.9×1.0
	Remarks	For connection of the IDU refrigerant system, it is recommended to use a soft copper tube (T2M), with the length selected according to the actual situation.	
	PVC water discharge pipe	Thermal insulation pipe	
	This is used as the IDU's drainage pipe, 25mm in diameter. The length is determined according to actual needs.		The thickness of the insulation pipe for the copper pipe is usually 10mm or above; and the thickness of the insulation pipe for the rigid polyethylene plastic tube is usually 15mm or above. If the pipe is used in a closed humid area, the thickness should be increased.

### [ Caution ]

The materials necessary for onsite installation of the copper pipe, air duct, flexible hose connecting the air outlet, drainage pipe, lifting screw, air supply and return grille, various fasteners (pipeline bracket, Victaulic connector, screw, etc.), power cable, signal line, etc. need to be purchased by the installer on site. The materials and specifications must comply with the corresponding local or industrial standards.

## Heat Insulation Material Requirements

### Copper pipe insulation

- ① Use the closed-cell foam insulation material, which is rated at a flame retardancy level of B1 and heat resistance of over 120°C.
- ② Thickness of the insulation pipe:
  1. When the diameter is equal to or greater than 15.9mm, the insulation thickness is at least 20mm.
  2. When the diameter is equal to or smaller than 12.7mm, the insulation thickness is at least 15mm.
- ③ For insulation of the outdoor copper pipe, the wall thickness of insulation pipes for winter heating systems is generally increased to at least 40mm in regions with severe cold. For insulation of the indoor gas pipe, the wall thickness of insulation pipes is usually greater than 20mm.
- ④ Use glue to connect the joints and cuts of the thermal insulation pipe, and then wrap them with electrical tape with a width of not less than 50mm to ensure the connection is firm.
- ⑤ The insulation between the copper pipe and the IDU should be tight to prevent the generation of condensed water.
- ⑥ After the system leakage detection test indicates that there are no leaks, carry out the insulation of the copper pipe.

### Air duct insulation

- ① Insulate the FCU components and the unit after the FCU system passes the air leakage test or quality check.
- ② Use centrifugal glass wool, rubber and plastic materials or other types of materials for thermal insulation. The insulation layer shall be smooth and dense without cracks or gaps.
- ③ The supports, suspension brackets, and brackets of the air duct shall be arranged outside the insulation layer with sole timber.
- ④ Insulation thickness:
  1. The thickness of the insulation layer shall not be less than 40mm if the layer is made of centrifugal glass wool and is used for the air supply pipes and air return pipes in rooms without air conditioning.
  2. The thickness of the insulation layer shall not be less than 25mm if the layer is made of centrifugal glass wool and is used for the air supply pipes and air return pipes in rooms with air conditioning.
  3. If the insulation layer is made of rubber and plastic materials or other materials, the thickness of the insulation layer shall be obtained according to design requirements or calculation results.

### Drainage pipe insulation

- ① Indoor parts of the drainage pipe shall be insulated to prevent condensation, and protective sleeves should be thicker than 10mm.
- ② If the pipe is not wholly insulated, be sure to rebind the cut part.
- ③ Use glue or buckles to connect the joints and cuts of the thermal insulation pipe, and make sure it is at the top of the pipe.
- ④ After the drainage test shows that there are no leaks, carry out the insulation of the water distribution pipe.

### [ Caution ]

The materials and specifications of insulation materials must meet national or industry standards.

# 3 Preparations Before Installation

## Unpacking Check

- ① Before installation, check whether the packing materials are in good condition, whether the accessories that come with the product are complete, whether the air conditioner is intact, whether the surfaces of the heat exchanger and other parts have become worn, and whether there are oil stains on the check valve of the unit.
- ② Check the two sealing nuts of the refrigerant pipe, and observe whether the red dot on the surface of the sealing nut of the gas pipe bulges. If it bulges, the pipe is well sealed; if it retracts, the line is leaking, and you need to contact your local dealer.
- ③ Check the machine model before installation.
- ④ After IDU and ODU inspection, pack them with plastic bags to avoid intake of foreign matters.

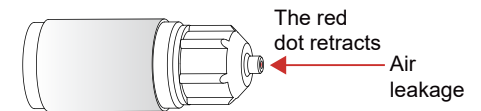
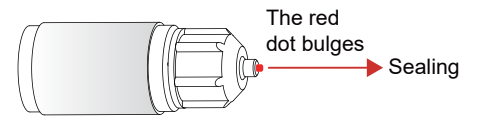

## IDU Positioning

Determine the positions of the air conditioning unit and lifting screws

- ① Determine the air outlet/return mode and the lifting position of the IDU according to the design drawing.
- ② Draw lines to locate the drilling positions of the bolts according to the three-dimensional diagram of the unit.
- ③ Make an access hole at the electric control box side (recommended size: 600×600mm).
- ④ For ease of disassembly of the motor, the rear end of the indoor unit shall be at least 200mm away from the wall.
- ⑤ There shall be no obstacle within 200mm of the return air inlet.
- ⑥ It is suggested to use an infrared ray locator for line drawing.

(Unit: mm)

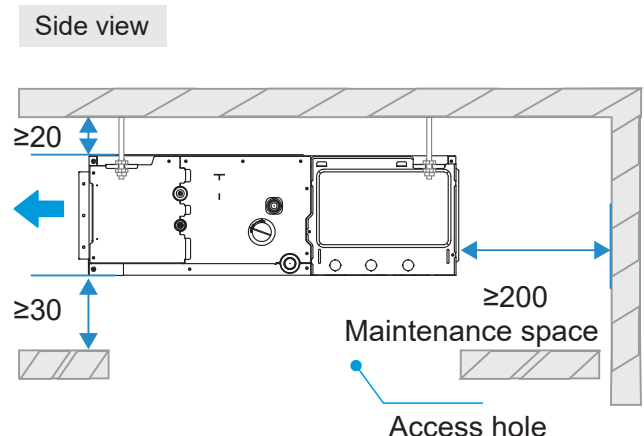
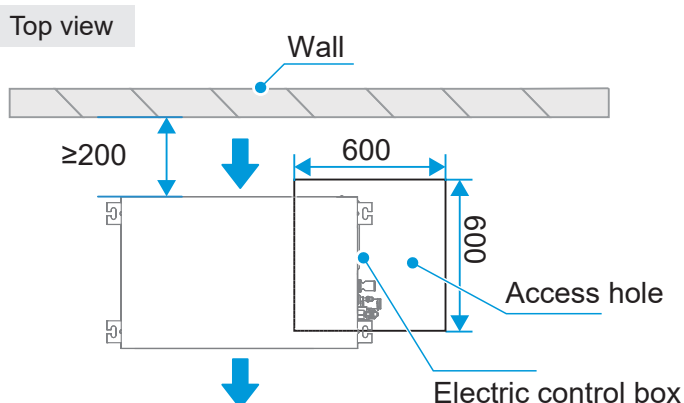



## Filter Installation

Install the filter outside the air return pipe, as shown in the Part Description section.

And secure all fixing holes with screws, Operated by installers.

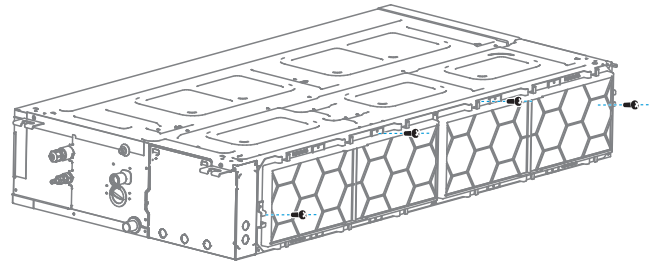

## Take out the package inside the propeller housing (for models 1.5~4.5, 11.2~16.0kW)

Before lifting the unit, always check the air outlet and air return plenum to ensure that the package and accessory package are taken out. Note that some models contain packaging material inside the propeller housing. Follow the steps below to remove it.

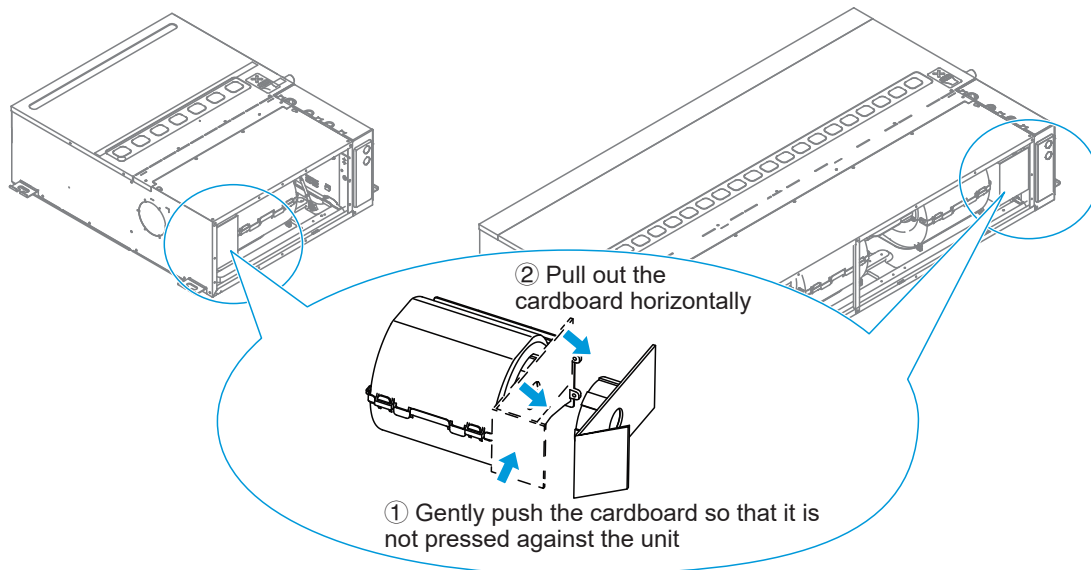

## Site adjustment of air return plenum

There are two air return modes for this series of models.

- ① One is the back air return which is the factory default.
- ② The other is the bottom air return which can be customized or adjusted on-site. Refer to the following two diagrams on the adjustment method.

Remove the back cover plate assembly

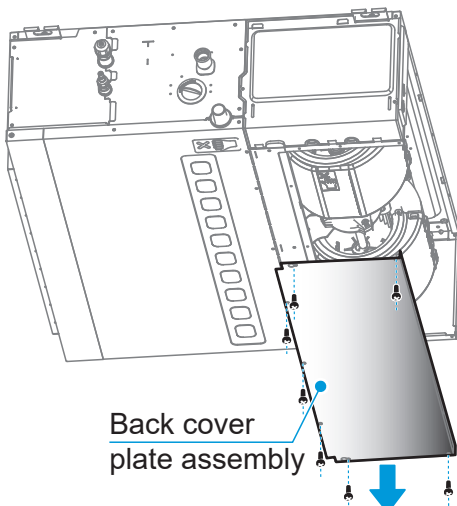

Install back cover plate assembly

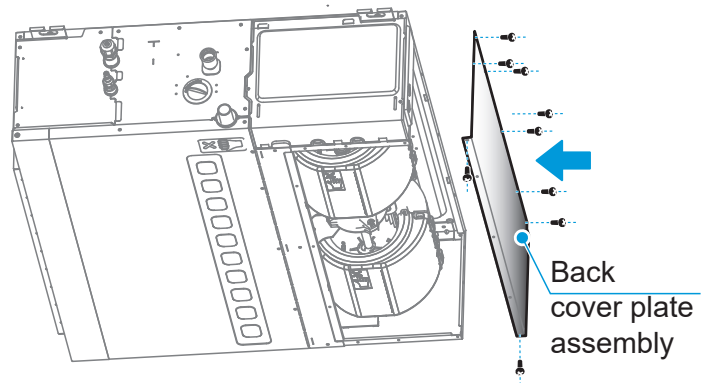

# 4 IDU Installation

## [ Warning ]

Install the air conditioner in a location with sufficient strength to support the weight of the unit. Take reinforcement measures when necessary.

The unit may fall and cause personal injury if the location is not strong enough.

Unstable installation may cause the unit to fall and cause an accident.

Before wiring/pipe layout, make sure that the installation area (walls and floor) is safe and free of water, power, gas, and other hidden dangers.

## Installation of lifting bolts

- ① Based on the distance between the four hanging holes of the indoor unit, use a pencil to draw the positions of screws to be fixed on the ceiling. After holes are drilled, tighten the expansion screws into the holes (by welding a fully threaded bolt of 490mm onto an expansion screw of  $\phi 8$ mm, with two screw caps), and then place the four corners of the indoor unit in the bolt to lift the unit.
- ② Use four hanger rods during lifting. The diameter of the lifting bolt shall not be less than 10mm. The hanger rods are strong enough to support two times the weight of the indoor unit, with two nuts tightened below the hanger rods.
- ③ When the length of the hanger rod exceeds 1.5m, two diagonal braces must be added to provide stability.
- ④ Removing the ceiling: Since building structures differ, discuss building details with the interior decoration workers.
  - a. Ceiling treatment: Reinforce the ceiling pedestal to make sure that the ceiling is level and to prevent ceiling vibrations.
  - b. Cut off and dismantle the ceiling pedestal.
  - c. Reinforce the remaining surface after the ceiling is removed. Add further reinforcements to the pedestal on two ends of the ceiling.
  - d. Once the main unit has been lifted and mounted, carry out the piping and wiring tasks within the ceiling. Determine the outlet direction of the piping after the installation site has been finalized.

For sites where the ceiling is already available, first connect and put in position the refrigerant piping, water discharge piping, and connecting wires of the IDU and wired controller before you hoist and mount the unit.

## [ Caution ]

High-quality carbon steel bolts (galvanized or with other anti-rust paint applied) or stainless steel bolts are used.

How the ceiling is treated will differ with the type of building. For specific measures, please consult the building and renovation engineers.

How the lifting bolt is secured varies according to the specific situation, and it must be secure and reliable.

## Installation of Lifting Bolts

Refer to the following figure on installation using the lifting bolts.

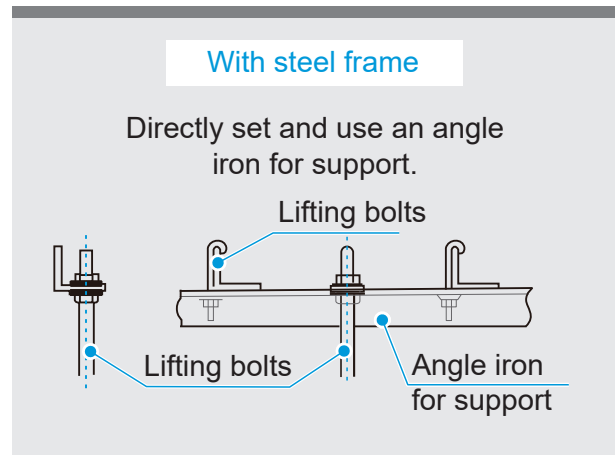
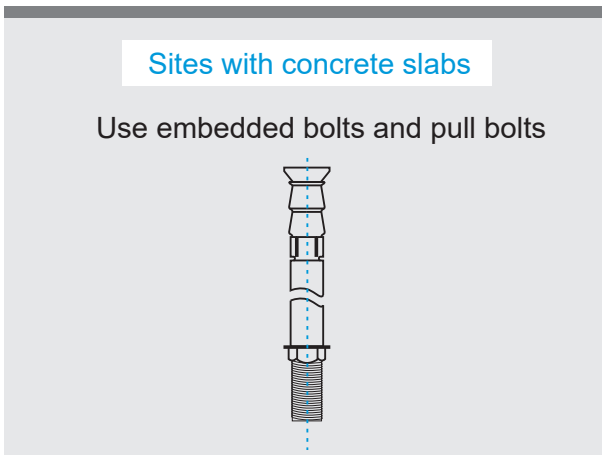

## IDU Installation

### [ Caution ]

The indoor unit must not be too close to the ceiling. It shall be installed level or at an angle within  $1^\circ$  towards the drainage side. (For units without a drain pump, ensure a slope of 1/100 towards the drainage side. Do not tilt towards the non-drainage side.) Otherwise, water cannot drain smoothly and leaks can easily occur.

Keep the indoor unit free from dust or foreign particles. Use the plastic bags provided with the product to cover the unit.

- ① Adjust the positions of the nuts. The size of the gap between the washer (bottom) and the ceiling should be based on the actual environment where the unit is being installed. The distance  $h$  between the lifting lug and the lifting bolt shall be kept within the range of 40mm-80mm, so as to facilitate the pipe connection and assembly and disassembly of the electrical appliance cover.

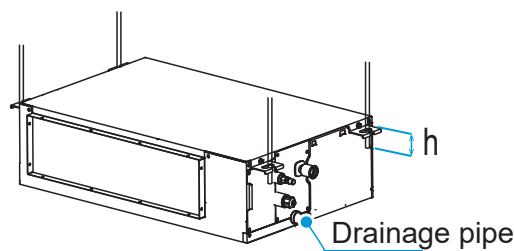

- ② Slot the lifting bolts in the oblong holes of the lifting lugs. Secure the top and bottom of lugs with washers and nuts.

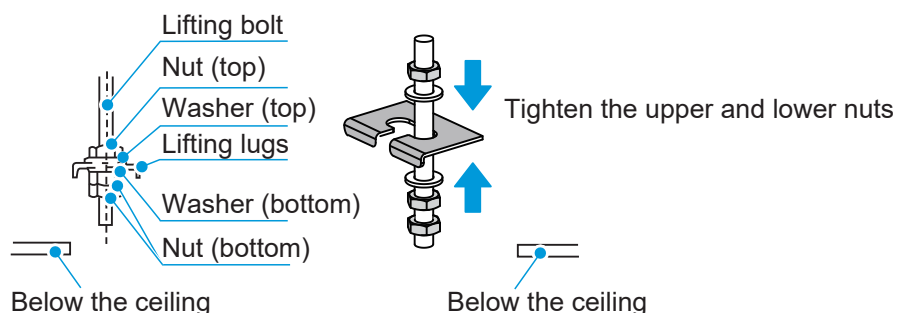

- ③ Use a transparent hose to observe the water level (principle of communicating vessels) and verify the levelness of the unit body in the depth direction. Keep the unit body level.

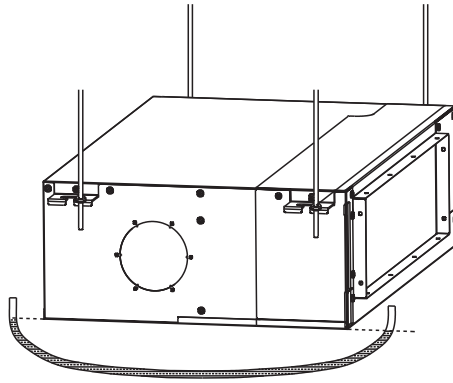

- ④ Use a transparent hose to observe water level (principle of communicating vessels) and verify the tilt angle of the unit body in the length direction, ensuring a downward slope of 1/100 towards the drainage side. Do not tilt it towards the non-drainage side.

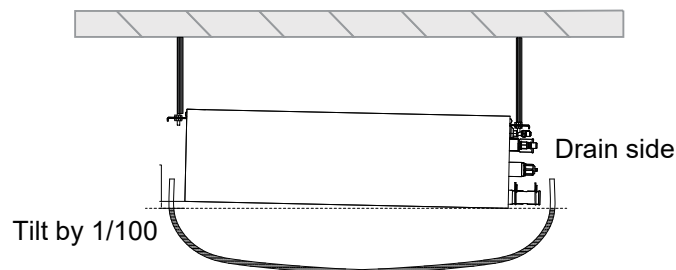

- ⑤ For units with fresh air functions, before installing IDUs, use diagonal pliers to remove the knockout at the fresh air unit at one side of the unit in advance. Install fresh air flanges at the fresh air unit and secure it with the flange connecting screws.

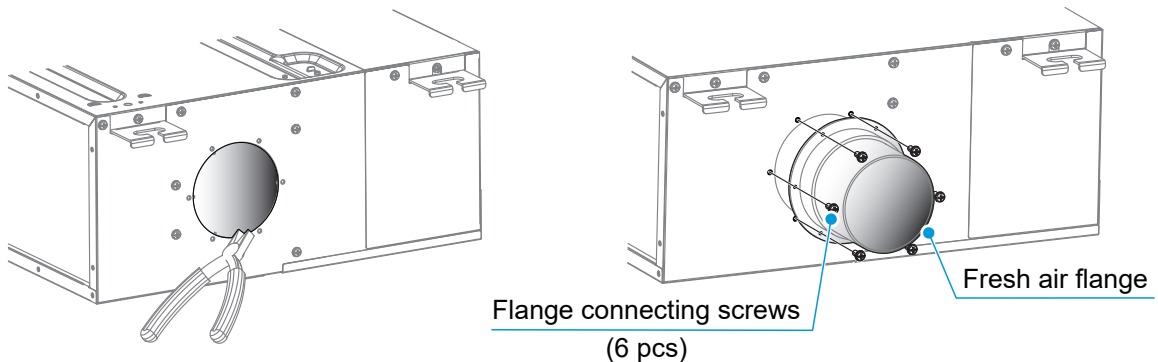

**⚠ [ Warning ]**

When connecting the fresh air unit, insulate the fresh air pipe with foam insulation materials that are at least 10mm thick.

The temperature difference between the fresh air provided by the fresh air unit to the IDU and the indoor temperature shall not exceed 5°C, otherwise there is a risk of condensation in the return air area of the air conditioner. Please use a fresh air unit equipped with a temperature regulation function. Or cover the enclosure of the fresh air outlet of the air conditioner with foam insulation material with a thickness of at least 10mm. The area and thickness of the insulation material should be adjusted depending on the actual situation.

## Air Inlet Panel for Air Return Plenum

### [ Caution ]



When designing the air inlet panel of the air return plenum, pay attention to the spacing between the air inlet grilles and try to keep the air inlet grilles in parallel with the air inlet direction.

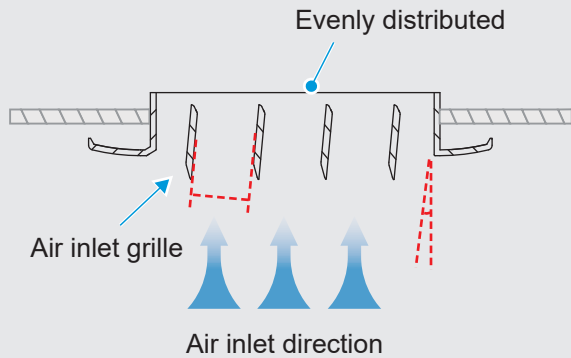

The spacing between return air grilles should be neither too large nor too small, and the angle between the air grilles and the direction of the air inlet should not be too large.

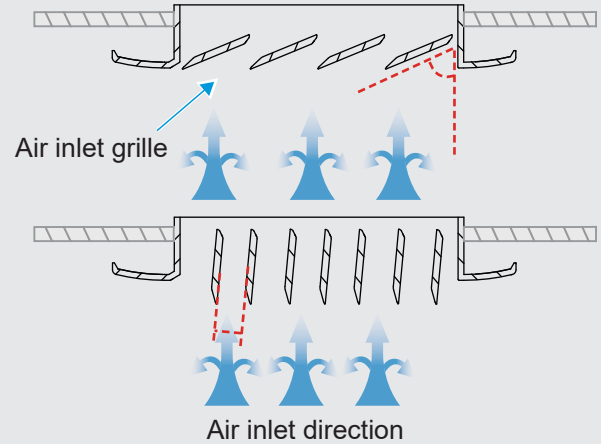

If the air outlet panel is far away from the unit body and needs to be connected to the outlet air flange through a metal air duct, make sure to attach a sponge to the metal contact surface to guarantee insulation.

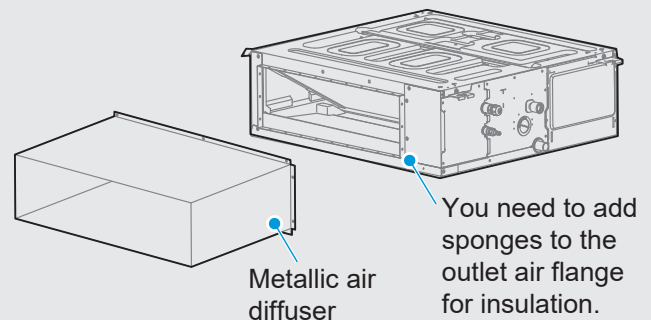

## 5 Refrigerant Connecting Piping Installation

Different ODUs have different requirements for length and level differences for the piping. Refer to the Installation & Owner's Manual attached with the ODU.

### [ Caution ]

During the installation of the connecting pipes, do not allow air, dust, and other debris to penetrate the piping system, and make sure the interior of the pipes is dry.

Install the connecting pipes only when the IDUs and ODUs are secured.

When installing the connecting pipes, record the actual installation length of the liquid pipe on the spot so that additional refrigerant can be added.

The copper pipes must be wrapped with thermal insulation materials when they are installed.

In the event of refrigerant gas leakage during operation, please ventilate immediately.

## Pipe Layout

- ① Bend the pipes or punch holes in the wall as needed. The deformed pipe area must not exceed 15% of the total area. A protective casing should be installed at the wall or floor hole. The weld joint must not be inside the casing. The drill hole on the external wall must be sealed and tightly wrapped with a binding tie to prevent impurities from entering the pipe. The pipe must be insulated with the correctly-sized insulation pipe.

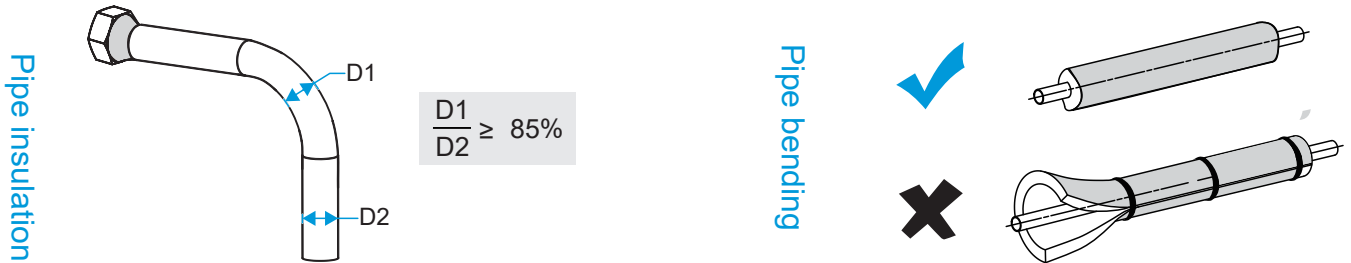

Note: D1 is the minimum diameter, and D2 is the nominal diameter.

- ② The wrapped connecting pipe is plugged through the wall hole sleeve from the outdoor side and enters the indoor side. The pipes must be arranged carefully so as not to damage the piping.

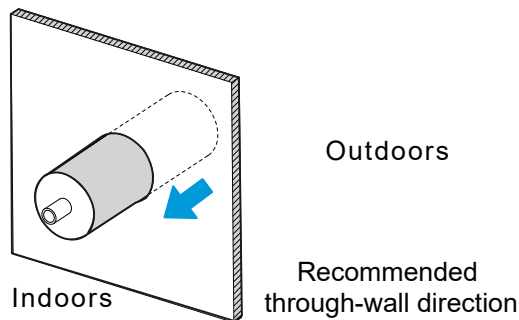

## Pipe Connection Steps

Measure the required length of the connecting pipe. Make the connecting pipe using the following method (see "Pipe Connection" for details).

- ① Connect the IDU first, then connect the ODU.
- Before tightening the flare nut, apply refrigeration oil on the inner and outer surface of the pipe flare (you must use refrigeration oil compatible with the refrigerant for this model), and turn it 3 or 4 turns by hand to tighten it.
- When connecting or removing a pipe, use two wrenches at the same time.

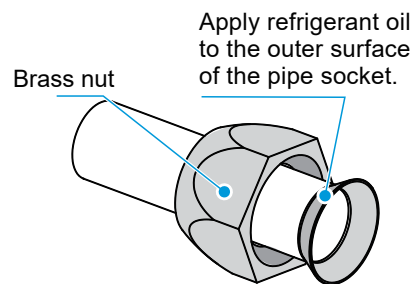

### [ Caution ]

✓ Bend and arrange pipes carefully without damaging the pipes and their insulating layers.



Do not let the interface of the IDU bear the weight of the connecting pipe; otherwise, the connecting pipe may be crushed and deformed, which will affect the cooling (heating) effect, or the thermal insulation materials may be compressed, resulting in air leakage and condensation.

- ② The check valve of the ODU is completely closed when leaving the factory. Unscrew brass nuts from the check valve in each connection, and connect the flared tube within 5 minutes. When the brass nuts at the check valve are removed and placed somewhere for too long, dust and other sundries may enter the pipeline system and cause failures after extended periods of operation.

- ③ After the refrigerant piping is connected to the IDU and ODU, follow the operations in "Vacuum pumping" to exhaust the air. After the air is exhausted, tighten the maintenance nut.

## Pipe Connection

Bend the pipe with your thumb



### Processing method

1. Hand bending processing: Applicable to thin copper pipes ( $\phi 6.35\text{mm}$ – $\phi 12.7\text{mm}$ ).
2. Mechanical bending processing: Wider application ( $\phi 6.35\text{mm}$ – $\phi 28\text{mm}$ ), using spring pipe bender, manual pipe bender or electric pipe bender.

### [ Caution ]

The bending angle should not exceed  $90^\circ$ ; otherwise, wrinkles will be formed in the pipe, which can easily break.

The bending radius should not be smaller than  $3.5D$  (pipe diameter) and should be as large as possible to prevent the pipe from becoming flattened or crushed.

When mechanically bending the pipe, the pipe bender inserted into the copper pipe must be cleaned.

## 1 Brazing pipes

When brazing pipes, fill the pipes with nitrogen. First evenly heat the inner pipes, then the outer pipes, and fill the joints with welding material.

### [ Caution ]

When it is necessary to fill the piping with nitrogen during welding, the pressure must be kept at  $0.02\text{MPa}$  using a pressure relief valve.

Do not use flux when soldering the refrigerant connection piping. Use a phosphor copper solder that does not require flux.

Do not use any antioxidants when soldering the piping. The piping may become clogged with residual antioxidants, which may block components such as electronic expansion valves during operation.

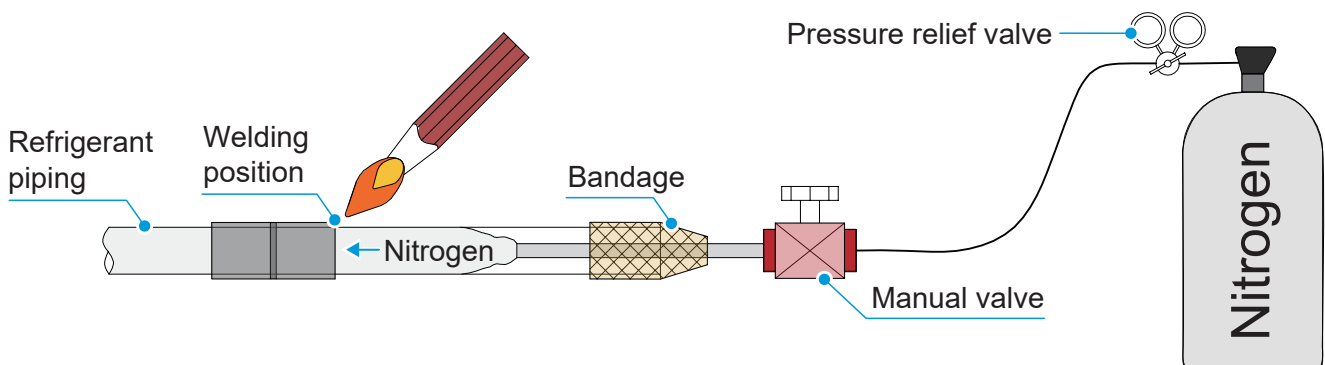

## 2 Flaring

To cut the piping with a pipe cutter, rotate the pipe cutter repeatedly.

Put the pipe into the connecting nut flaring, and both the gas pipe and liquid pipe of the IDU are connected by flaring.

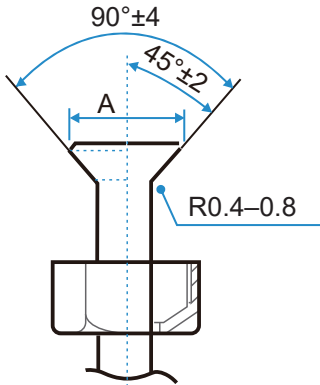
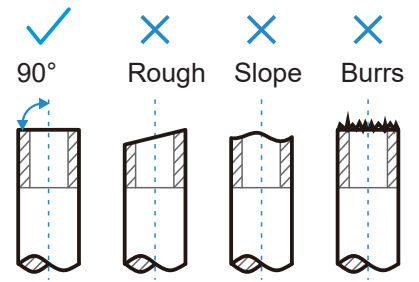
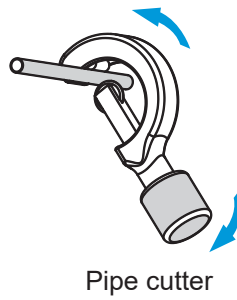

Outer diameter (mm)	A (mm)	
	Max.	Min.
Φ6.35	8.7	8.3
Φ9.52	12.4	12.0
Φ12.7	15.8	15.4
Φ15.9	19.1	18.6
Φ19.1	23.3	22.9

## 3 Nut fastening

- Align the connecting piping, firstly tighten most of the thread of the connecting nut by hand, and then use a wrench to tighten the last 1-2 turns of the thread as shown in the figure.
- The welding is done on site, and the bell mouth cannot be used indoors. (For IEC/EN 60335-2-40 except IEC 60335-2-40: 2018)
- The protective nut is a one-time part, it can not be reused. In case it is removed, it should be replaced with a new one. (For IEC 60335-2-40: 2018 only)

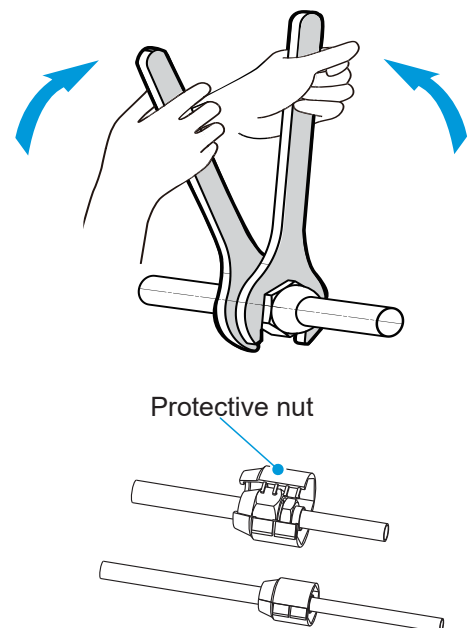
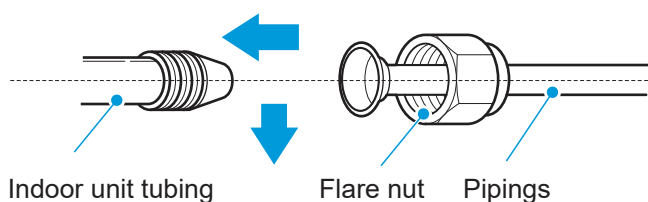
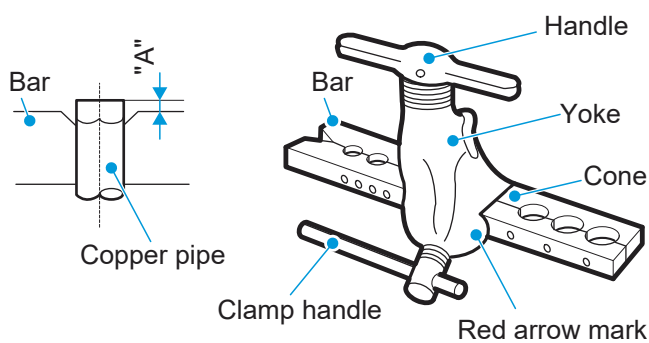



## [ Caution ]

Excessive torque can break nut on installation conditions.

When flared joints are reused indoors, the flare part should be re-fabricated.

Pipe size (mm)	Tightening torque [ N.m (kgf.cm)]
Φ6.35	14.2–17.2 (144–176)
Φ9.52	32.7–39.9 (333–407)
Φ12.7	49.5–60.3 (504–616)
Φ15.9	61.8–75.4 (630–770)
Φ19.1	97.2–118.6 (990–1210)

## [ Caution ]

Depending on the installation conditions, excessive torque will damage the flared mouth, and too small torque cannot tighten the nut, which will cause refrigerant leakage. Please refer to the above table to determine the appropriate tightening torque.

## Refrigerant Piping Fixing

Angle iron brackets or round steel hangers should be used for fixing. When the liquid pipe and gas pipe are suspended together, the size of the liquid pipe shall prevail.

Pipe outer diameter (mm)	≤20	20~40	≥40
Horizontal pipe distance (m)	1.0	1.5	2.0
Stand pipe distance (m)	1.5	2.0	2.5

## Vacuum Pumping

Connect the refrigerant piping to the gas and liquid pipes of the ODU, and use a vacuum pump to evacuate the gas and liquid pipes of the ODU at the same time.



Do not use the refrigerant enclosed in the ODU for vacuuming. The reduction of ODU refrigerant may cause performance degradation of the air conditioner.

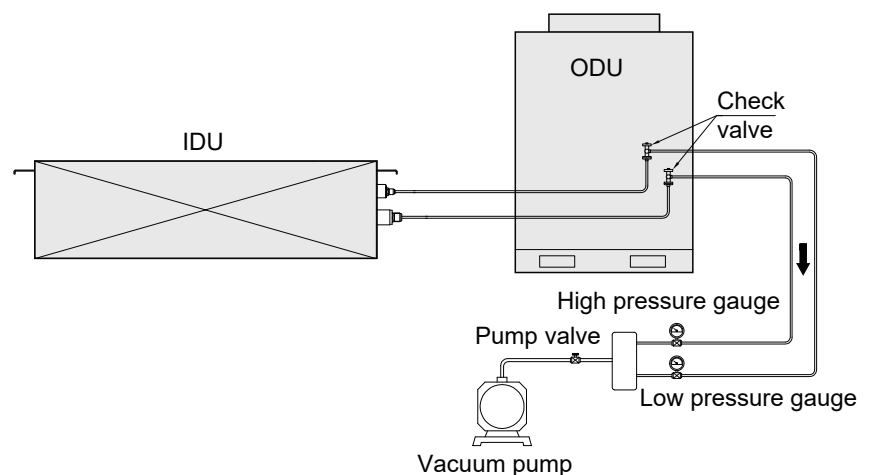

## Leak Detection

Fill the system with nitrogen and increase its pressure to detect leaks. The following methods are recommended:

### 1. By foam

Apply soapy water or foam evenly (spray) on areas where leakage may occur, and observe whether air bubbles appear. If there are no air bubbles, it indicates that the system is airtight.

### 2. By instrument

Use a refrigerant leak detector to identify leaks. Align the leak detector probe with the part where leakage may occur, and follow the instructions to determine whether there is a leak.

## [ Caution ]

Leak detection will be conducted at each spot for at least 3 minutes. If any leak has been identified, tighten the nut and perform the detection again until no leaks are found. After completing the leak detection, wrap the exposed IDU pipe joint with insulation material and tie it with a binding tie to prevent condensation and dripping water.

## Heat Insulation Treatment

Pipes on the liquid and air sides have a low temperature during cooling. Take sufficient insulation measures to prevent condensation.



- Be sure to use a thermal insulation material with a heat resistance of 120°C or higher for the gas pipe.
- The attached insulation material for the part of the IDU where the pipe connects must undergo heat insulation treatment that leaves no gaps.
- For outdoor pipelines, additional protective treatments should be performed, such as adding metal duct boxes or wrapping the pipes with aluminum foil materials. Thermal insulation materials directly exposed to the open air will degrade and lose their insulating properties.

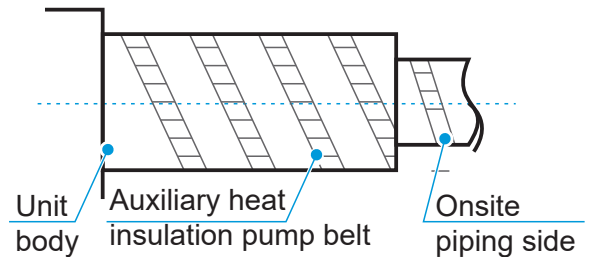

# 6 Drainage Pipe Installation

## [ Caution ]

Before installation of the condensate pipeline, determine its direction and elevation to avoid intersection with other pipelines to ensure that the slope is smooth and straight.

The highest point of the drainage pipe should be equipped with a discharge port to ensure the smooth discharge of condensate water, and the discharge port must face downwards to prevent dirt from entering the pipe.

Do not connect the drainage pipe to the wastewater pipe, sewage pipe, or other pipes that produce corrosive gases or odors. Otherwise, the IDU (especially the heat exchanger) may be corroded and odor may enter the room, negatively impacting the heat exchange effects and user experience. The user will assume responsibility for any consequences resulting from failure to abide by instructions.

After the pipeline connection is completed, a water test and a full water test should be done to check whether the drainage is smooth and whether the pipeline system leaks.

The air conditioner drainage pipe must be installed separately from other sewage pipes, rainwater pipes and drainage pipes in the building.

Adverse slope, convex and concave pipes are prohibited, as improper airflow will cause poor drainage.

Drainage pipes need to be evenly wrapped with thermal insulation pipes to prevent condensation.

Please connect the drainage pipes in the following ways. Improper installation of the pipes may result in water leakage and damage to furniture and property.

All joints of the drainage system must be sealed to prevent water leakage.

## Installation of Water Discharge Pipe for the IDU

Units without pumps: Use the attached drainage hose to connect to the drain pan outlet and PVC pipe, and fasten the two ends of the drainage hose with a cable tie. Then push the thermal insulation pipe to be closely attached to the main body, and finally fasten the end with a cable tie.

- ① Units with pumps: Connect a PVC pipe to the water pump outlet, and fasten it with a cable tie. Then push the thermal insulation pipe until it is closely attached to the main body, and finally fasten the end with a cable tie. The connection between the two ends of the drainage pipes and the connection of the water pump outlet need to be fastened with a cable tie, in combination with PVC/rubber adhesives. Pay attention to the instructions for the use of the adhesives to prevent corrosion to the EPDM rubber. Use hard PVC adhesives for connecting to other water piping. Check that the connections are tight with no leakage.

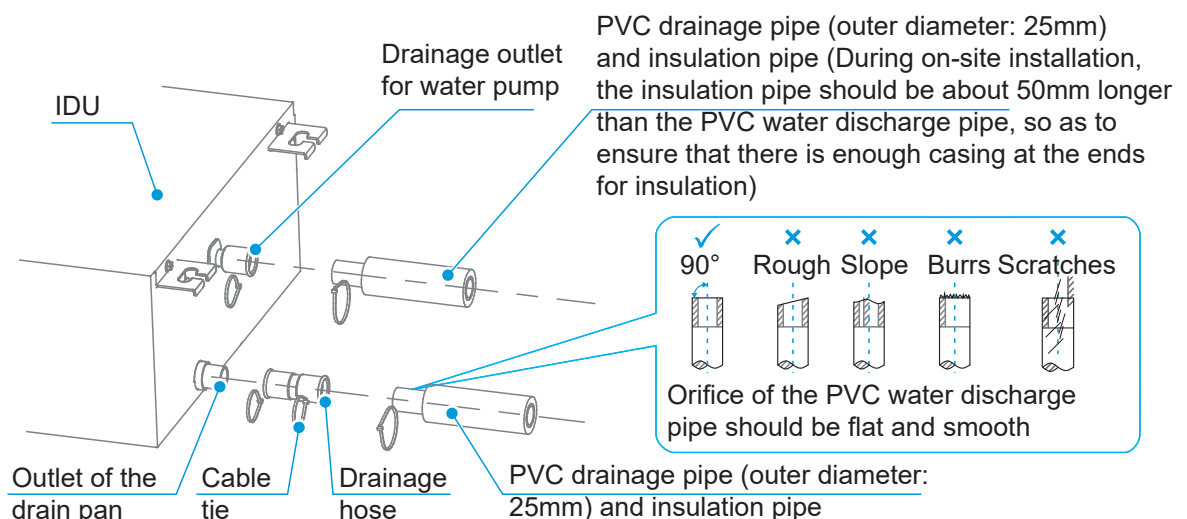

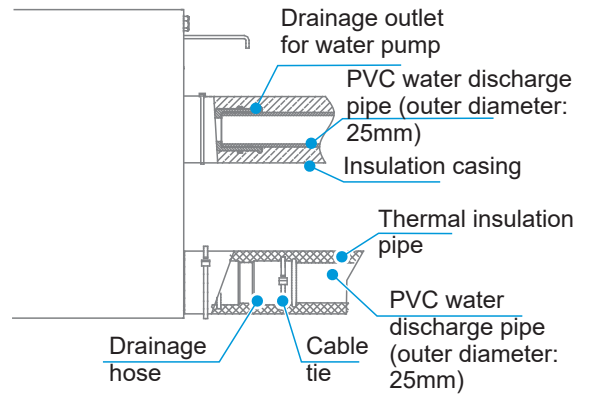
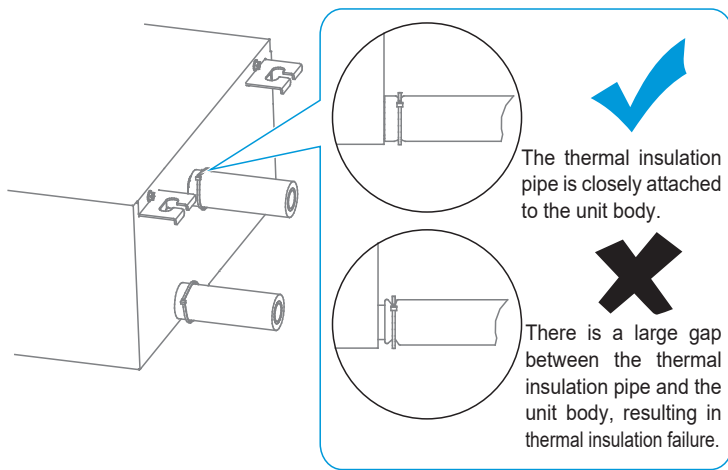

- ② The water pump connecting pipe and drainage pipe (in the indoor part) must be wrapped with heat insulation pipe evenly and bound with cable ties to prevent air from entering and producing condensate.

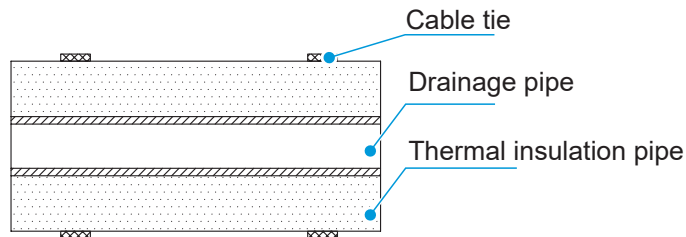

- ③ To prevent water from flowing back into the air conditioner when it stops running, the drainage pipe should be inclined downward to the outdoor side (drainage side), with a downward slope of 1/100 or above. The drainage pipe should be positioned in the same direction as the drainage outlet of the unit body in the left and right direction, so that the drainage pipe does not expand and collect water; otherwise, it may cause abnormal noise.

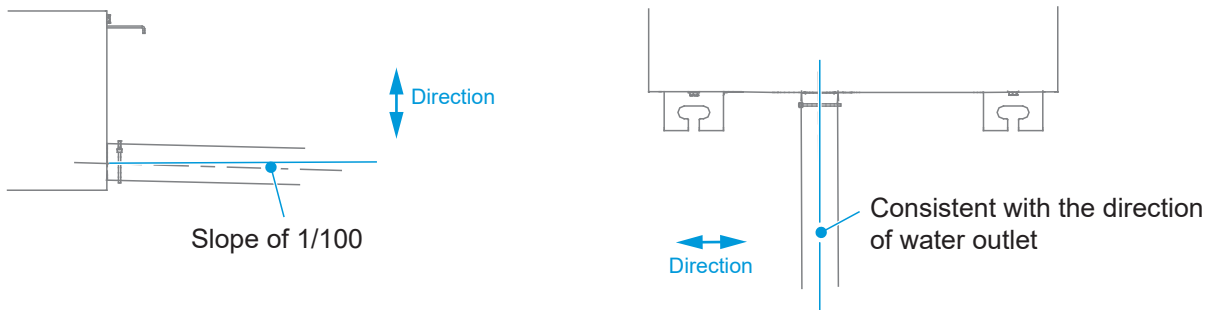

- ④ When connecting the drainage pipe, do not pull the drainage pipe forcefully, or it may become loose. The lateral length of the drainage pipe should be within 20m, and a support point should be set every 0.8–1.0m to avoid air resistance caused by the deformation of the drainage pipe. The drainage pipe shall be equipped with a support point every 1.5-2.0m.

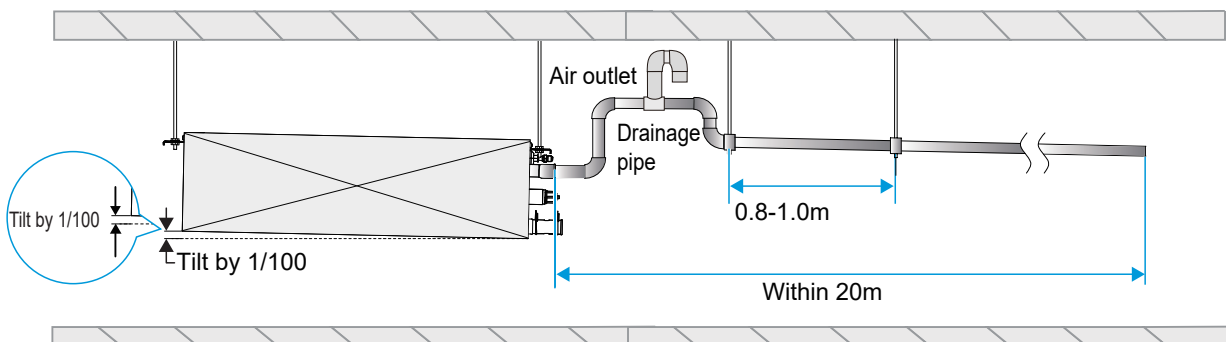

⑥

The end of the drainage pipe must be more than 50mm above the ground or from the base of the water discharge slot. In addition, do not submerge it in water. To discharge the condensed water directly into a ditch, the water discharge pipe must bend upwards to form a U-shaped water plug to stop odors from entering the room via the water discharge pipe.

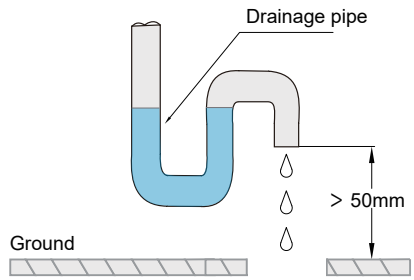

- Method to discharge water with the drain pump:

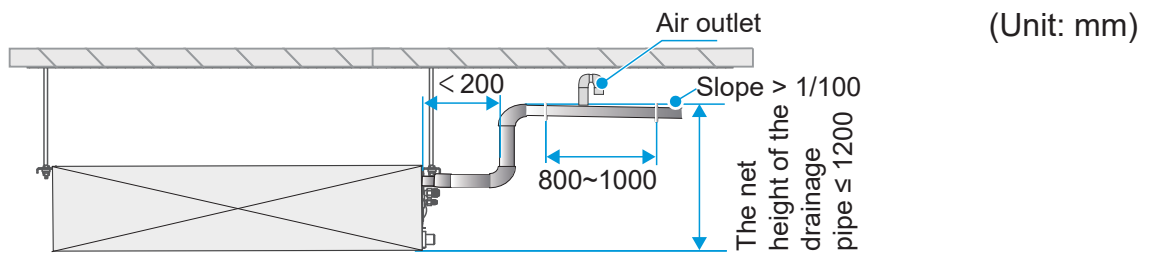

How to connect the drainage pipe for the drain pump of a single unit

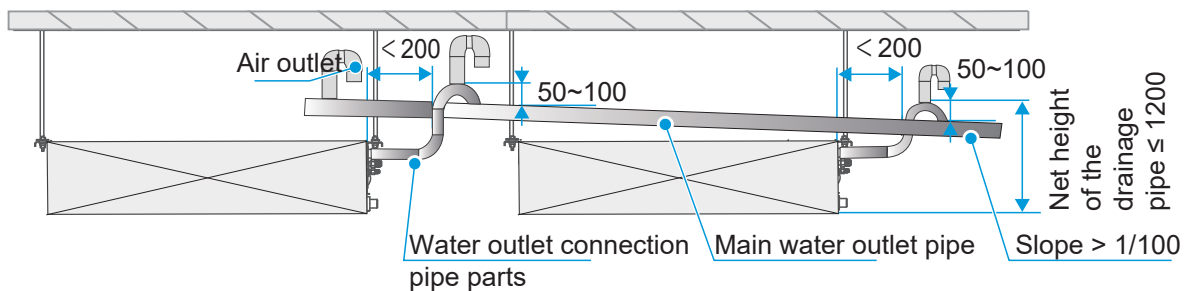

Drainage pipes from drain pumps of multiple units are connected to the main drainage pipe to be discharged through the sewage pipe.

- Hedging must be prevented for horizontal drainage pipes to avoid adverse slopes and poor drainage.

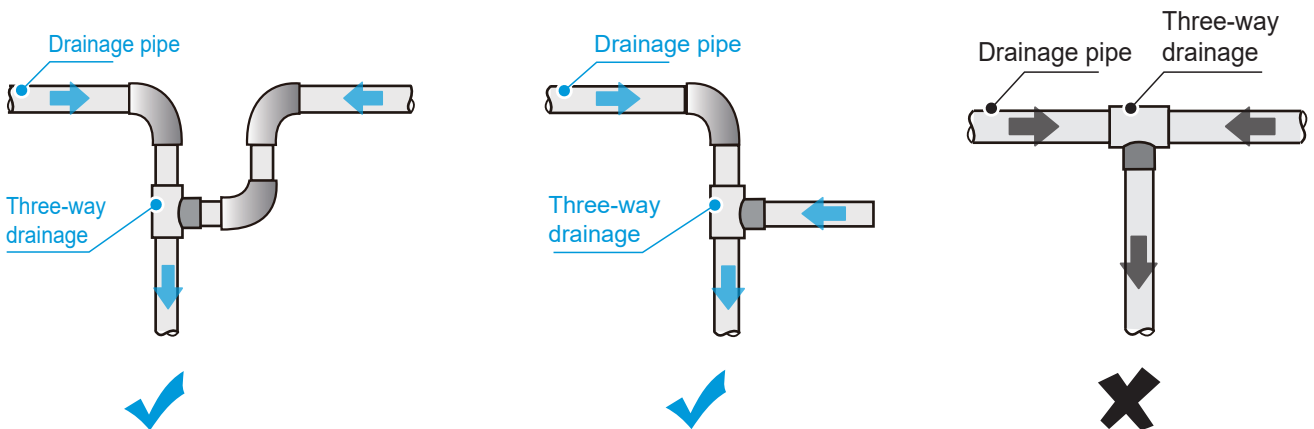

- How to discharge water without the drain pump:

(Unit: mm)

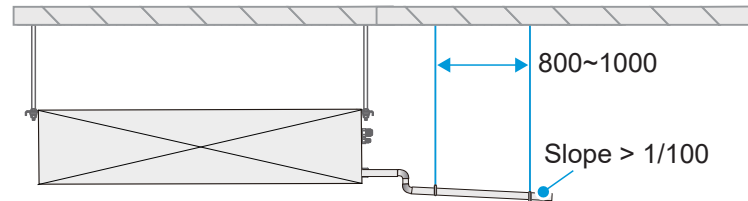

Method to connect the drainage pipe for a single unit

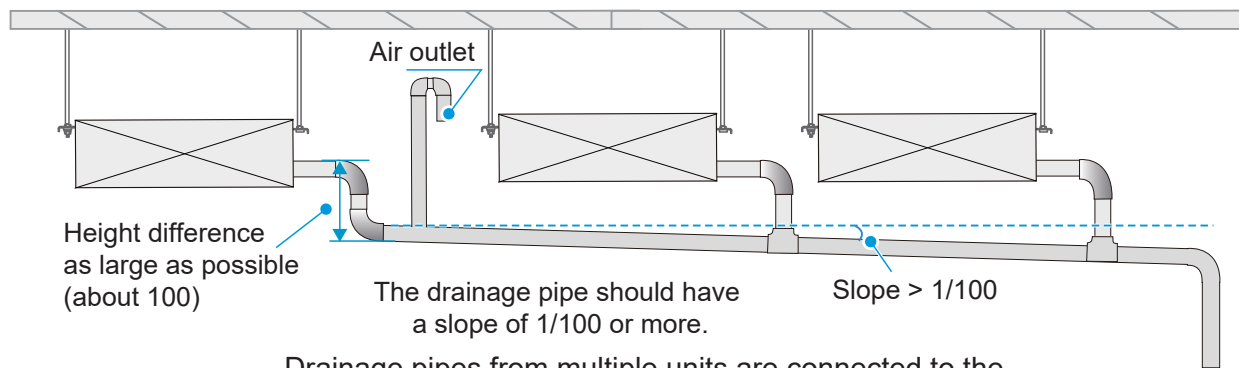

Drainage pipes from multiple units are connected to the main drainage pipe to be discharged through the sewage pipe.

## Water Discharge Test

- ① Before the test, make sure that the water discharge pipeline is smooth, and check that each connection is properly sealed.
- ② Conduct the water discharge test in a new room before the ceiling is plastered.
  - Inject water into the drain pan with the water injection pipe. The amount of water injected is shown in the table below.
  - Connect the power supply, and set the air conditioner to operate in cooling mode. Check whether drainage outlets normally discharge water (based on drainage pipe length, water will be drained 1 minute later), and check connectors for leakage.
  - If water is discharged through the IDU drain pump, loosen the water cover (black round plastic piece) on the unit during the drainage test and check whether the drain pump is operating. If the drain pump has not been started, check whether the drain pump has malfunctioned. Note: The drain pump only starts in cooling mode. While in heating mode, the drain pump remains turned off. After the water discharge test is completed, install the water cover assembly in position. For details on the water cover assembly and the water injection pipe, see figure below.

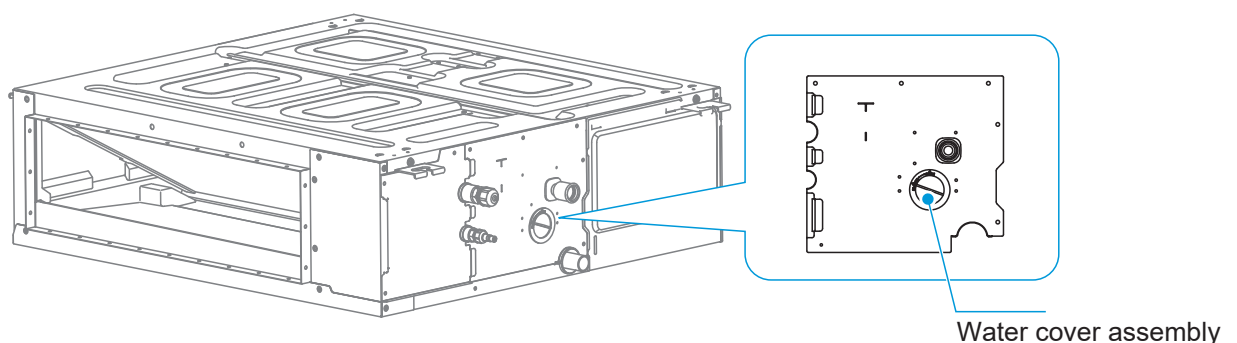

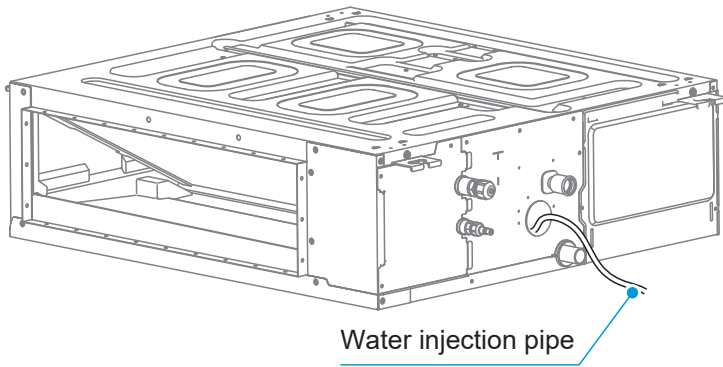

Water injection amount: (Unit: ml)

IDU capacity (kW)	Water injection amount
$\text{kW} \leq 4.5$	1500
$4.5 < \text{kW} \leq 7.1$	1800
$7.1 < \text{kW} \leq 9.0$	2200
$11.2 < \text{kW} \leq 16.0$	3000

## 7 Air Duct Installation

- ✓ Please use locally purchased air ducts and soft air ducts (Use environmentally friendly, odorless materials, otherwise the air conditioner may generate odor when it runs).
- ✓ Install the flange at the air return side, and use aluminum foil tape to seal the connection part between the flange and the air duct to avoid air leakage.
- ✓ Use aluminum foil tape to seal the connection part between the flange at the air supply side and the air duct to avoid air leakage.
- ✓ The air ducts on the air supply side shall be insulated to prevent condensation.
- ✓ When installing the air duct and its components, you need to fix and adjust the supports and suspension brackets to ensure they are in the right position and subject to uniform force.
- ✓ Make sure that the air duct and its components are clean before installation.
- ✓ After installation, carry out the air tightness test on the air duct to ensure its air leakage meets China's standards.

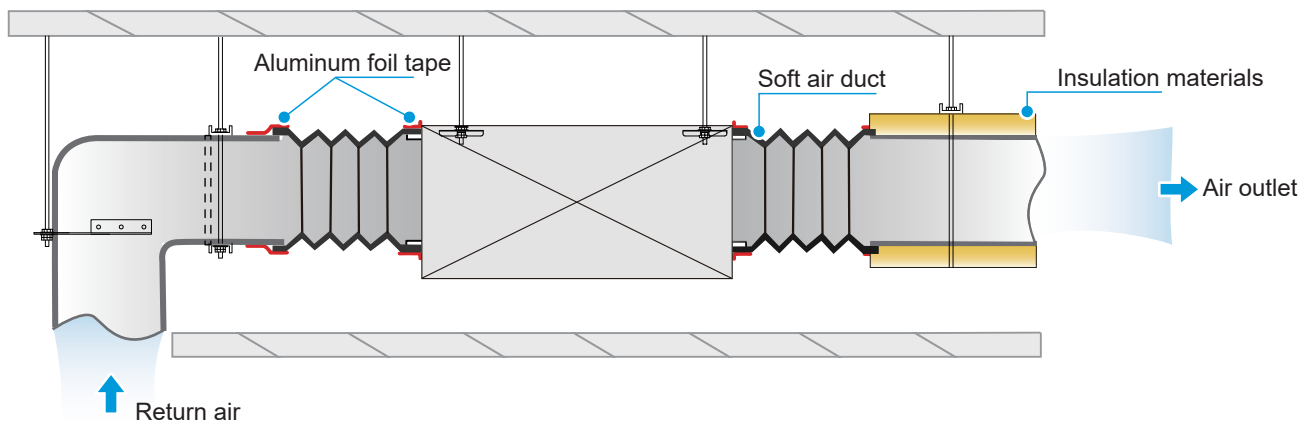

## [ Caution ]

Connect the air outlet and return air inlet to the ceiling opening properly to avoid short circuit caused by return air. (See the figure below)

Use canvas or soft air duct to connect the IDU and air duct at a distance (width) of 150-300mm.

Do not lay wires, cables or other pipes containing toxic, flammable, and explosive gases or liquids inside the air ducts.

The air duct regulating device shall be installed in a position that is easily accessible, flexible, and reliable.

The air duct should be securely connected to the vent.

The frame shall fit snugly into the building decoration, and should appear neat and flexible. It shall not be twisted or warped.

If the air vent is installed horizontally, its deviation shall not exceed 3/1000; if installed vertically, its deviation shall not exceed 2/1000.

All the air vents in one room shall be neatly installed at the same height.

All metal accessories (including supports, suspension brackets, and brackets) for the piping system shall undergo anti-corrosion treatment.

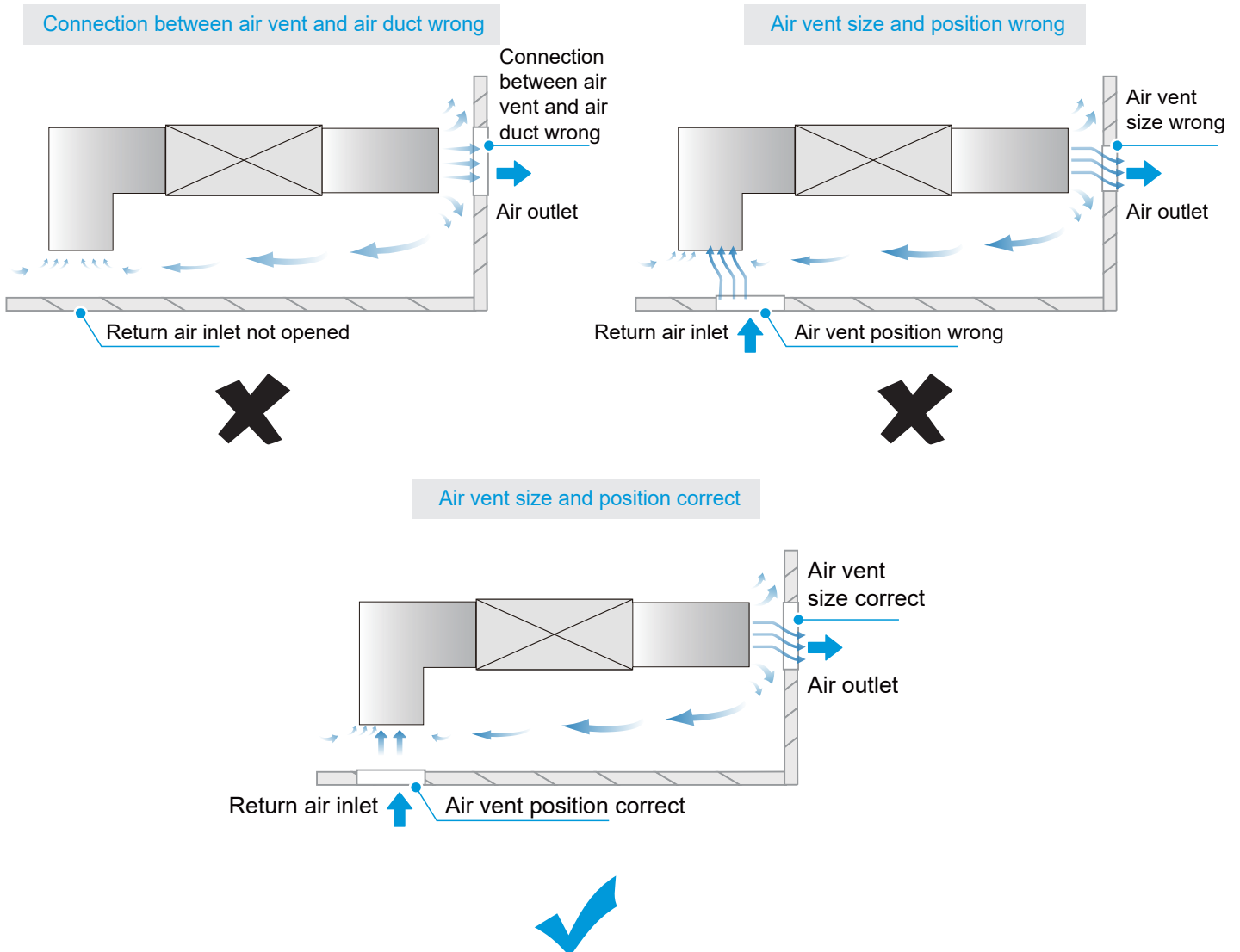



# 8

## Electrical Connection

### [ Danger ]

The power supply must be cut off before any electrical work is carried out. Do not conduct electrical work when the power is on; otherwise, it may cause serious personal injury.

The air conditioning unit must be grounded reliably and must meet the requirements of the local country/region. If the grounding is not reliable, serious personal injury due to electric leakage may occur.

### [ Warning ]

Installation, inspection or maintenance operations must be completed by professional technicians. All parts and materials must comply with the relevant regulations of the local country/region.

The air conditioning unit must be equipped with a special power supply, and the power supply voltage should conform to the nominal working voltage range of the air conditioning unit.

The power supply of the air conditioning unit must be equipped with a power disconnect device that conforms to the requirements of relevant local technical standards for electrical equipment. The power disconnecting device must be equipped with short circuit protection, overload protection and electric leakage protection. The clearance between open contacts of the power disconnecting device shall be at least 3mm.

The core of the power cable must be made of copper, and the wire diameter should meet the current-carrying requirements. For details, refer to the "Power Cable Diameter and Electric Leakage Protector Selection". A wire diameter that is too small may cause the power cable to heat up, resulting in a fire.

The power cable and the ground wire should be secured reliably to avoid stress on the terminals. Do not pull the power cable forcibly; otherwise, the wiring may become loosened or the terminal blocks may be damaged.

Strong current wires such as power cables cannot be connected to weak current wires such as communication lines; otherwise, the product may be seriously damaged.

Do not bond and connect the power cable. Bonding and connecting the power cable may cause it to heat up, resulting in a fire.

### [ Caution ]

Avoid bonding and connecting the communication line. If doing so is unavoidable, at the very least, ensure a reliable connection by crimping or soldering and make sure the copper wire at the connection is not exposed; otherwise, communication failure may occur.

The power cable and communication line must be routed separately, with a distance of over 5 cm. Otherwise, communication failure may occur.

Keep the vicinity of the air conditioning unit as clean as possible to avoid small animals from nesting and biting the cables. If a small animal touches or bites the cables, short circuiting or electric leakage may occur.

Do not connect the ground wire to the gas pipe, water pipe, lightning rod ground wire or telephone ground wire.

Gas pipe: Risk of explosion and fire when gas leaks.

Water pipe: If rigid plastic pipes are used, there will be no grounding effect.

Lightning rod ground wire or telephone ground wire: In the event of lightning strikes, abnormal ground potential may rise.

After all wiring is completed, check carefully before turning on the power supply.

## Electrical Characteristics

Unit power (kW)	Electric specifications of the IDU					
	Frequency (Hz)	Voltage (V)	MCA (A)	MFA (A)	IFM power input (W)	FLA (A)
1.5	50	220~240	0.63	15	50	0.50
2.2			0.63		50	0.50
2.8			0.63		50	0.50
3.6			0.80		50	0.64
4.5			1.2		50	0.95
5.6			1.2		60	0.95
7.1			1.5		60	1.2
8.0			1.5		240	1.2
9.0			1.6		240	1.3
11.2			2.3		240	1.8
12.5			2.3		240	1.9
14.0			2.3		240	1.9
16.0			2.8		240	2.2

### Notes:

MCA: Min. Circuit Amps. (A), which is used to select the minimum circuit size to ensure safe operation over a long period of time.

MFA: Max. Fuse Amps. (A), which is used to select the circuit breaker.

IFM power input: full load power input of the indoor fan motor (reliable operation at the fastest speed setting).

FLA: Full Load Amps. (A), which is the full load current of the indoor fan motor (reliable operation at the fastest speed setting).

# Schematic diagram of the main terminal blocks of main control board

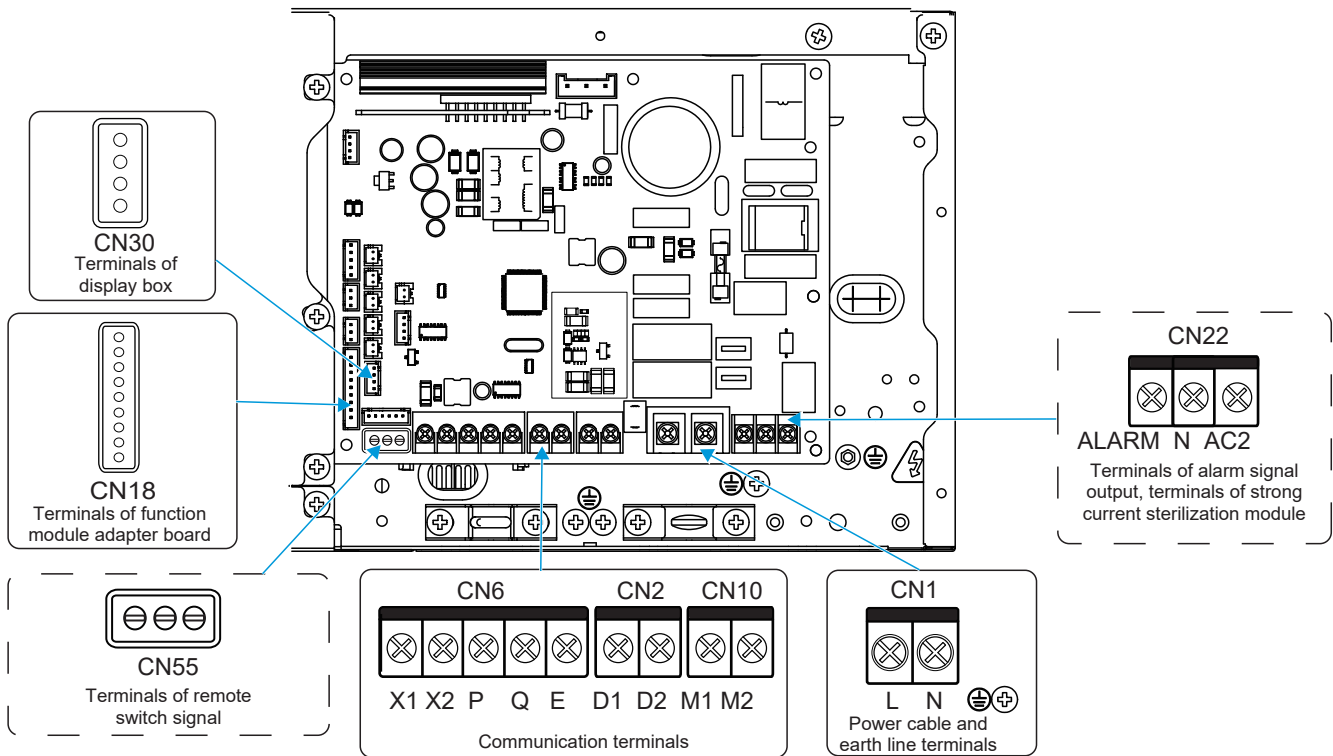

## [ Caution ]



All weak point connection points meet SELV, such as X1, X2, P, Q, E, M1, M2, CN18, CN55 etc.

## Wiring

- 1 Open the IDU's electric control box cover.
  - ① Remove the two screws at the positions shown in the figure;
  - ② Pull the bottom end of the electric control box cover horizontally outward;
  - ③ Remove the electric control box cover by pulling downwards.

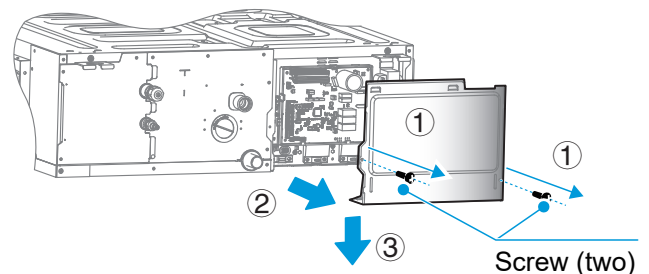

- 2 Connect the strong current wires (power cable, alarm signal output wire, and strong current sterilization wire) and weak current wires (communication line, display box connection wire, remote switch connection wire, function expansion board connection wire) to the electric control box through the bottom of the electric control box, and the strong and weak current inlets.

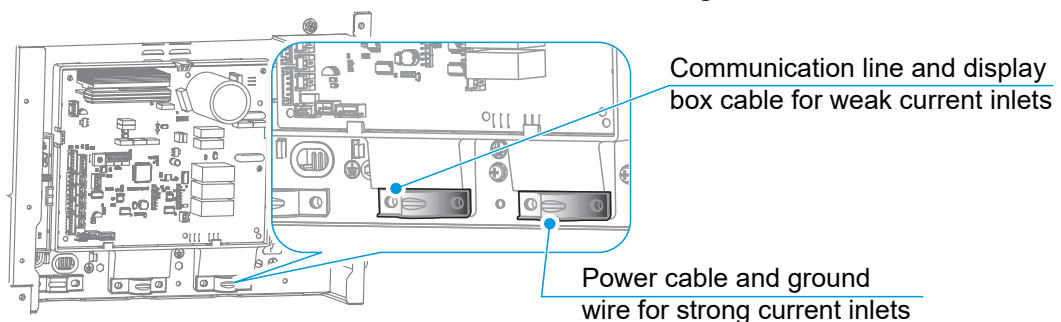

## [ Caution ]

The strong and weak current wires must be separated.

The strong current sterilization module and function expansion board are optional.

### 3 Power cable connection

#### ① Connection between the power cable and power supply terminal

The power supply terminal of the IDU is fixed on the main control board, the power cable is connected to the power supply terminal labeled "CN1" on the main control board. The live and neutral wires are connected according to the main control board logos "L" and "N", and the ground wire is directly connected to the electric control box sheet metal part.

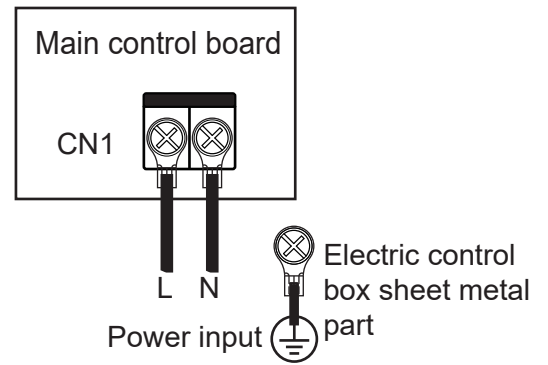

#### [ Caution ]

**A** Do not bond and connect the power cable. Bonding and connecting the power cable may cause it to heat up, resulting in a fire.

**B** The power cable must be crimped reliably using an insulated circular terminal block, and then connected to the power supply terminal of the IDU, as shown in the figure below.

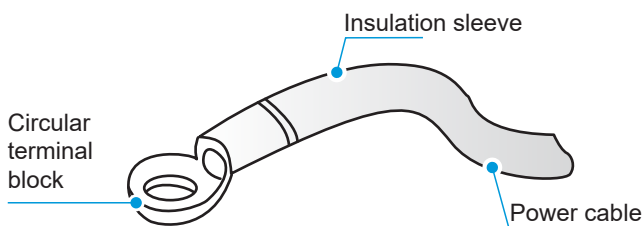

**C** If it fails to crimp the insulated circular terminal block due to on-site limitations, connect the power cables of the same diameter to both sides of the power supply terminal block of the IDU, as shown in the figure below.

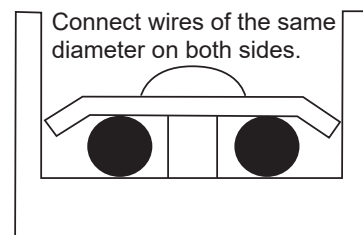

**D** Do not press the power cables of the same wire diameter on the same side of the terminal. Do not use two power cables of different wire diameters for the same terminal blocks; otherwise, they can easily loosen due to uneven pressure and cause accidents, as shown in the figure below.

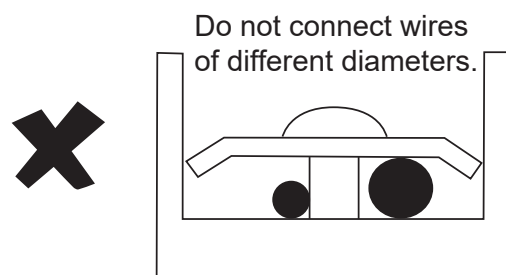
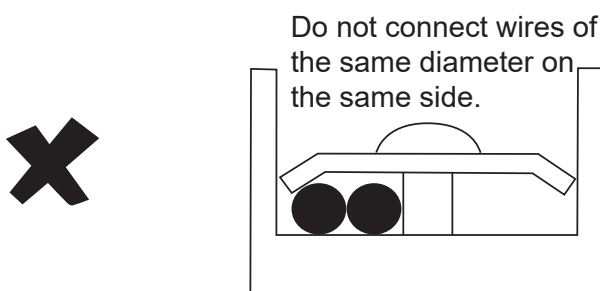

**E** The connected power cable should be secured with a wire clamp to prevent loosening, as shown in the right figure.

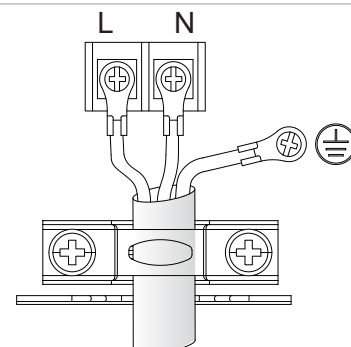

## ② Power cable system connection

Power cable system connection depends on the forms of communication between the IDU and ODU. For the HyperLink communication form, IDUs are allowed to have independent power supplies. For other communication forms, IDUs should be provided with uniform power supplies.

**A** IDUs are provided with independent power supplies\*, which are wired as follows:

For HyperLink communication with independent power supply:

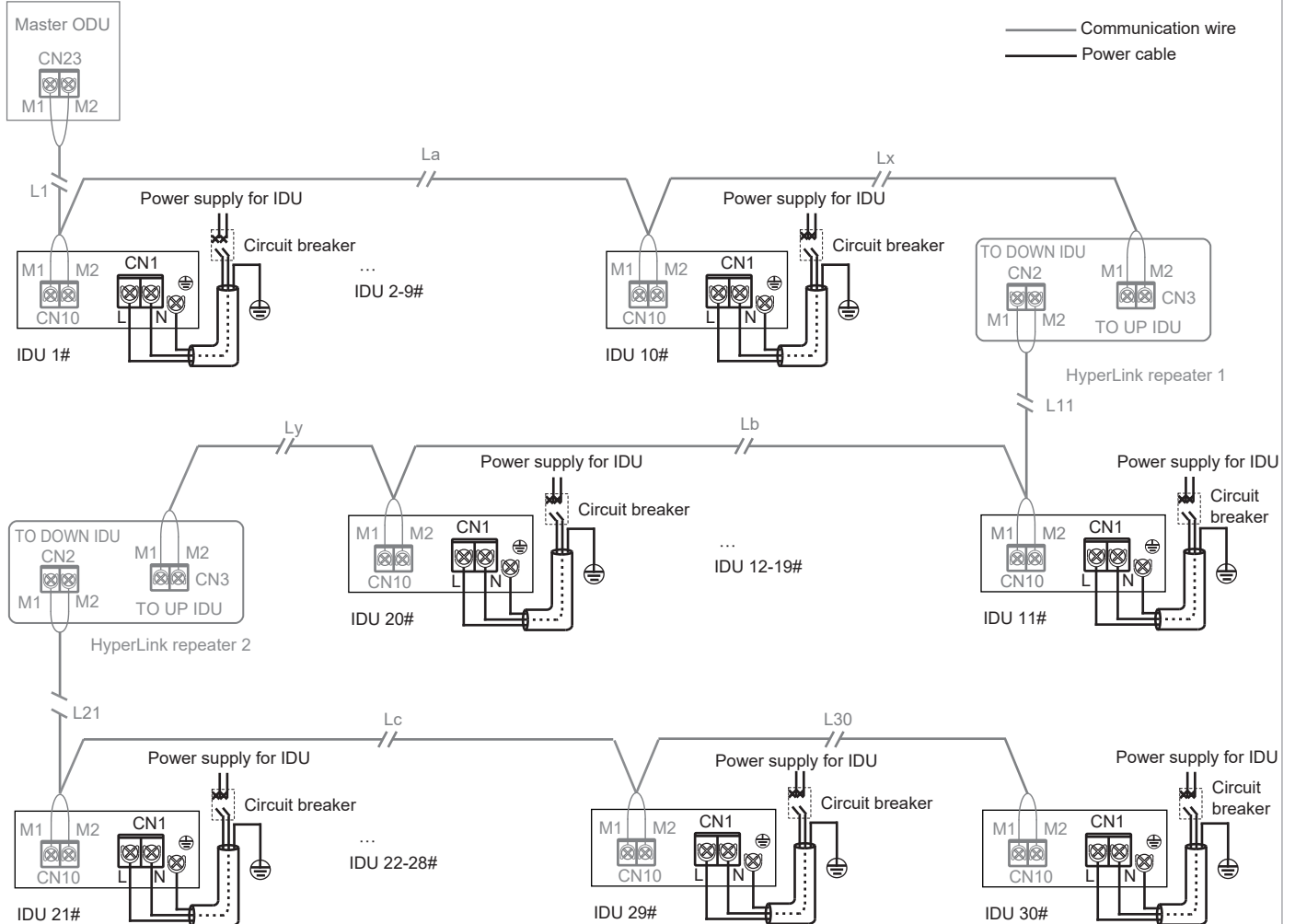

### [ Caution ]

When the IDUs are provided with independent power supplies, the IDUs in the same refrigerant system should be V8 IDUs\*, and the communication between IDUs and ODU adopts a HyperLink with an independent power supply.

This connection method has the function of an independent power supply, so in the same refrigerant system, the number of IDUs must not exceed 30 sets, and a maximum of only two repeaters may be installed\*.

One repeater shall be added for every 10 IDUs or a communication distance of 200m added.

## B IDUs are provided with uniform power supply\*, which are wired as follows:

### 1. HyperLink communication with the uniform power supply:

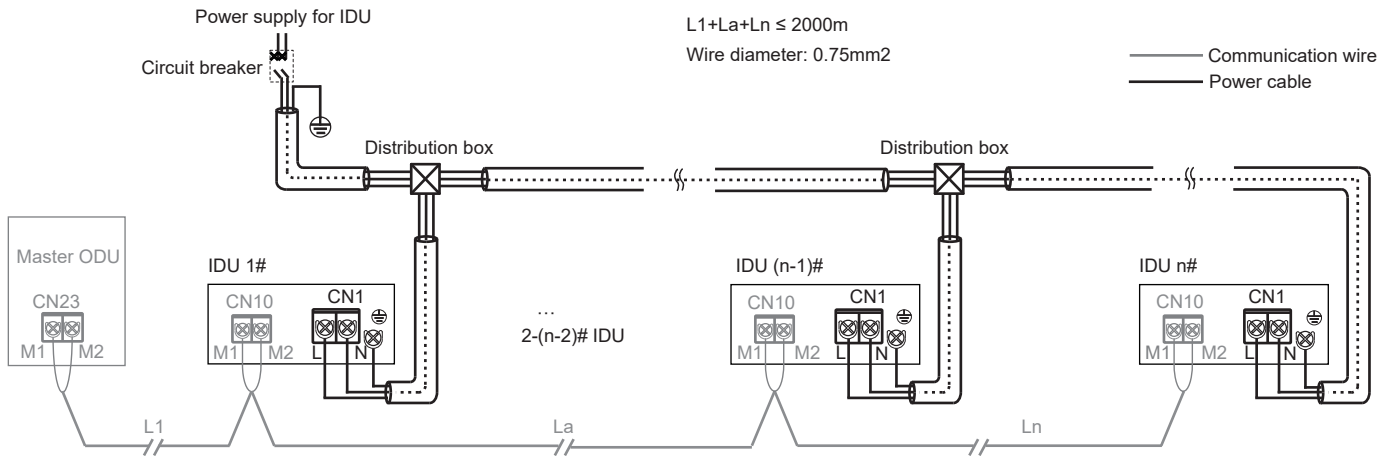

### 2. P/Q communication:

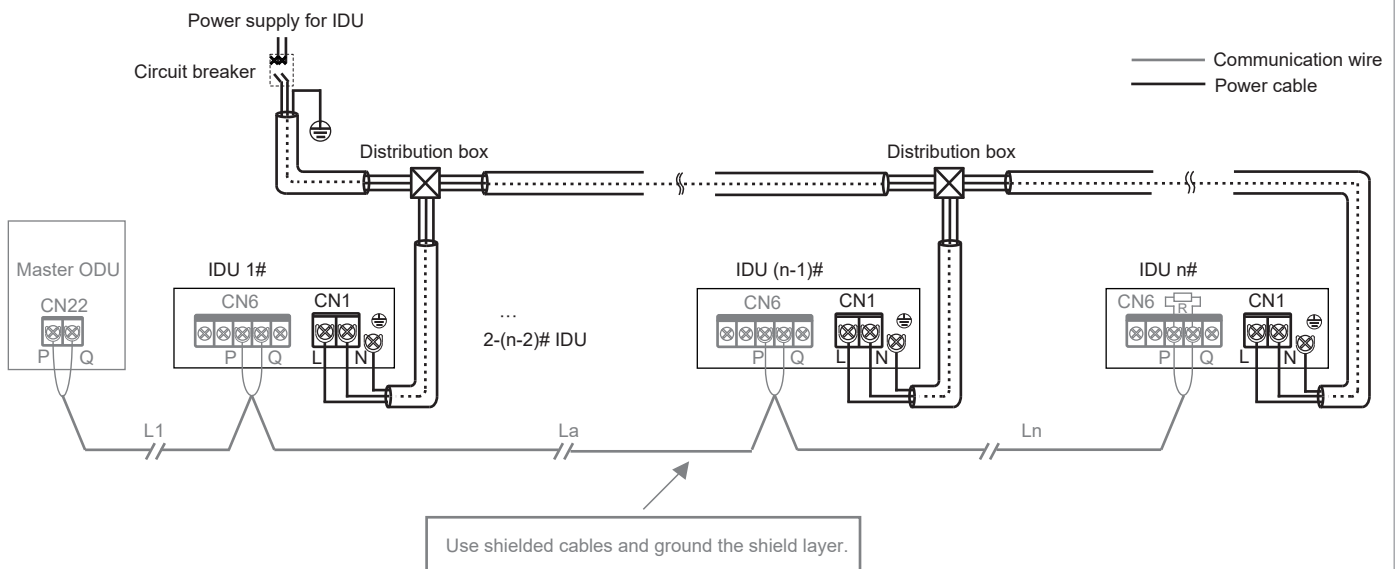

### 3. P/Q/E communication:

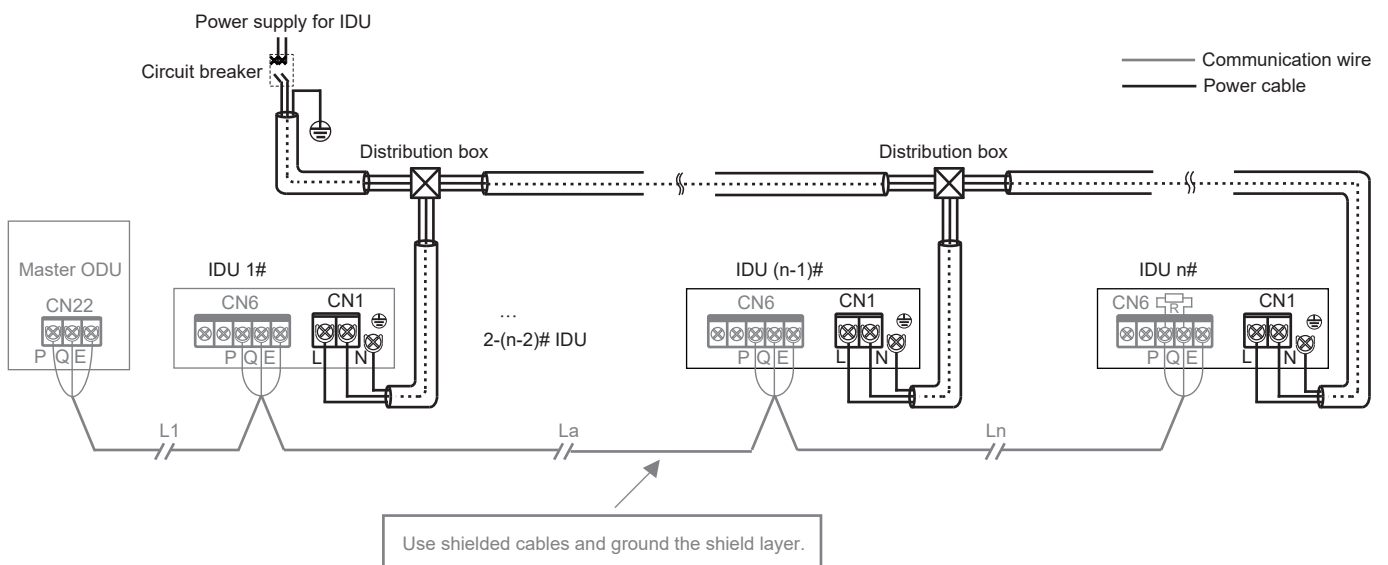

## [ Caution ]

When the IDUs are provided with a uniform power supply, if the IDUs in the same refrigerant system are V8 IDUs, then IDUs and ODU can communicate either via HyperLink with a uniform power supply, or via P/Q. If some of the IDUs in the same refrigerant system are non-V8 series, then IDUs and ODU can only communicate via P/Q or P/Q/E communication.

Both P/Q communication and HyperLink communication (M1M2) are indoor and outdoor communication, and only one of them can be selected. Do not connect P/Q communication and HyperLink communication at the same time in the same system. Do not connect HyperLink communication to P/Q or D1D2 communication.

## [ Note ]

V8 IDUs: with V8 printed on the packaging carton

Independent power supply: With separate circuit breakers, the power supply for each IDU can be controlled independently.

Uniform power supply: All the IDUs in the system are controlled by one circuit breaker.

Repeater: power supply repeater, which is used to compensate for the pressure drop due to excessive length of line or line resistance when the main control board of ODU provides independent power supply for IDUs through the HyperLink communication line. It is only used in refrigerant systems where IDUs are provided with an independent power supply.

## 4 Communication line connection

### ① Selection of communication method for IDUs

Equipped with independently developed HyperLink (M1M2) communication, V8 series IDUs also preserve the previous RS-485 (PQE) communication method. They are compatible with non-V8 IDUs. Pay attention to the type of IDU you have purchased before connecting communication lines. Please refer to the following table to select an appropriate communication method.

IDU type	Optional communication method between IDUs and ODU	Remarks
Are all the IDUs in the system V8 series	HyperLink (M1M2) communication	<ol style="list-style-type: none"><li>1. Independent power supply for IDUs*.</li><li>2. Any topology connection of communication lines.</li><li>3. Two-core and non-polar communication for M1M2.</li></ol>
	RS-485 (PQ) communication	<ol style="list-style-type: none"><li>1. The IDUs need to be powered uniformly.</li><li>2. The communication cables must be connected in serial.</li><li>3. Two-core and non-polar communication for PQ.</li></ol>
Are some of the IDUs in the system non-V8 series	RS-485 (PQE) communication	<ol style="list-style-type: none"><li>1. The IDUs need to be powered uniformly.</li><li>2. The communication cables must be connected in serial.</li><li>3. PQE cables must be 3-core and PQ non-polar.</li></ol>

② Table of selection of communication line diameter

Function	IDU and ODU communication				One controller to one IDU (Two controllers to one IDU) Communication	One-to-more (centralized controller) Communication
Item	HyperLink communication (IDUs are powered independently)	HyperLink communication (IDUs are powered uniformly)	P/Q communication (IDUs are powered uniformly)	P/Q/E communication (IDUs are powered uniformly)	X1X2 communication	D1D2 communication
Wire diameter	2 × 1.5mm <sup>2</sup> Wire resistance ≤ 1.33Ω/100m	2 × 0.75mm <sup>2</sup>	2 × 0.75mm <sup>2</sup> (shielded cable)	3 × 0.75mm <sup>2</sup> (shielded cable)	2 × 0.75mm <sup>2</sup> (shielded cable)	2 × 0.75mm <sup>2</sup> (shielded cable)
Length	≤ 600m (add two repeaters)	≤ 2000m	≤ 1200m	≤ 1200m	≤ 200m	≤ 1200m

 [ Caution ]

Please select the communication line according to the requirements in the above reference table. Use shielded cables for communication when strong magnetism or interference is present.

On-site wiring must comply with the relevant regulations of the local country/region and must be completed by professionals.

Do not connect the communication line when the power is on.

Do not connect the power cable to the communication terminal; otherwise, the main control board may be damaged.

The standard value of the screw torque of the communication line terminal is 0.5N·m. Insufficient torque may cause poor contact; excessive torque may damage the screws and power supply terminals.

Both HyperLink communication and PQ communication are internal and external, so only one of the two can be selected. Do not connect both HyperLink communication line and PQ communication line to the same system, otherwise the IDU and ODU cannot communicate normally.

If some of the IDUs in the same refrigerant system are non-V8 series, only P/Q/E communication can be selected for the IDU and ODU communication. The three-core shielded cable of 3×0.75mm<sup>2</sup> is required to connect "P", "Q", and "E".

Do not bundle the communication line with the refrigerant pipeline, power cable, etc. When the power cable and the communication line are laid in parallel, a distance of more than 5cm should be maintained to prevent interference from the signal source.

When the construction personnel of the IDU and ODU are working separately, information communication and synchronization are required. Do not connect the ODU to HyperLink and the IDU to PQ. Do not connect the ODU to PQ and the IDU to HyperLink.

Bonding and connecting the communication line should be avoided, but if it is used, at the very least, ensure a reliable connection by crimping or soldering and make sure the copper wire at the connection is not exposed; otherwise, communication failure may occur.



### ③ IDU and ODU communication

#### A HyperLink communication (with independent power supply)

Single unit: HyperLink communication is a new type of IDU and ODU communication technology. When the IDUs are provided with independent power supplies, use 2×1.5mm<sup>2</sup> communication cables. M1 and M2 ports are located at terminal block "CN10" of the main control board. There is no distinction between negative and positive electrodes. For details, see the following figure:

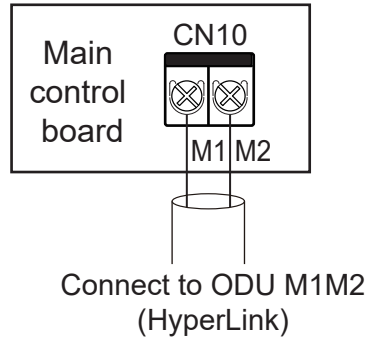

#### [ Caution ]

Do not connect the HyperLink communication line to the PQ or D1D2 communication line.

System: The HyperLink communication line with an independent power supply between IDU and ODU can reach a length of up to 600 meters, supporting any topology connection. The following figure shows a serial connection:

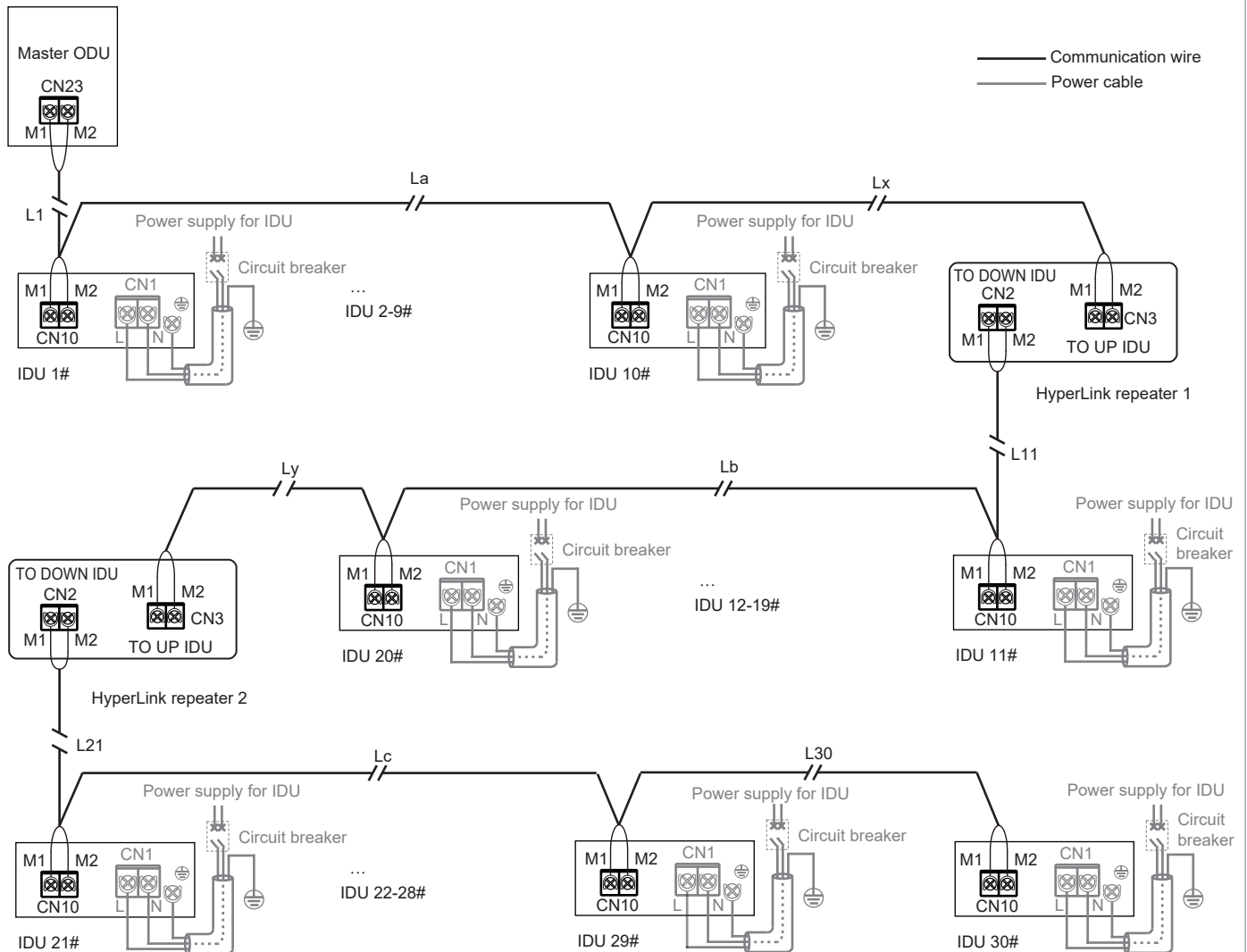

$$L1+L_a+L_x \leq 200m \quad L_{11}+L_b+L_y \leq 200m \quad L_{21}+L_c+L_{30} \leq 200m$$

For other connection methods (tree topology, star topology, ring topology), please refer to the technical manual or consult technical personnel.

## [ Caution ]

If the total distance is  $\leq 200\text{m}$  and the total number of IDUs is  $\leq 10$  sets, the valve is powered and controlled by the master ODU.

If the total distance is longer than 200m or the total number of IDUs is more than 10 sets, a repeater is required to increase the bus voltage.

The load capacity of the repeater is the same as that of the ODU, and it can load a bus length of 200m or 10 IDUs.

The number of IDUs requiring power supply in the same refrigerant system does not exceed 30 sets.

A maximum of two repeaters can be installed in the same refrigerant system.

Keep the power on/off for both the repeater and the ODU, or use an uninterruptible power supply.

For repeater installation, refer to the repeater installation manual. Do not connect the upstream and downstream IDU ports of the repeater in reverse; otherwise, it will cause a communication failure.

The repeater is optional. If you need to purchase it, please contact your local dealer.

## **B** HyperLink communication (with uniform power supply)

Single unit: When the IDUs are provided with uniform power supply, it is not necessary for HyperLink communication line to provide an independent power supply for IDUs. In this case, use  $2 \times 0.75\text{mm}^2$  communication cables. M1 and M2 ports are located at terminal block "CN10" of the main control board. There is no distinction between negative and positive electrodes. For details, see the following figure:

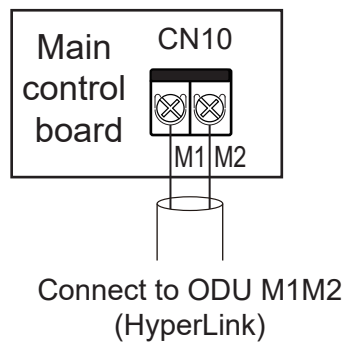

## [ Caution ]

Do not connect the HyperLink communication line to the PQ or D1D2 communication line.

System: The HyperLink communication line with a uniform power supply between IDU and ODU can reach a length of up to 2000 meters, supporting any topology connection. The following figure shows a serial connection:

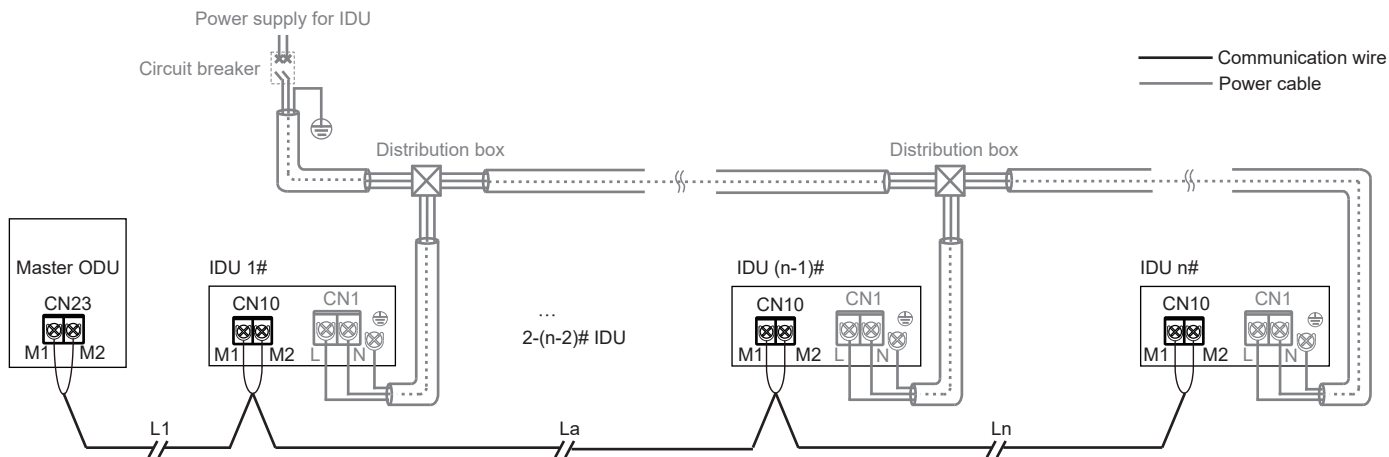

$$L1+La+Ln \leq 2000m$$

For other connection methods (tree topology, star topology, ring topology), please refer to the technical manual or consult technical personnel.

### [ Caution ]

When HyperLink with a uniform power supply is available, a uniform power supply for IDUs is required. For details, see "Power Cable Connection".

When HyperLink with a uniform power supply is available, there is no need to connect a repeater to the system.

### C P/Q communication

Single unit: Use a shielded cable for the P/Q communication and properly ground the shield layer. P and Q ports are located at terminal block "CN6" of the main control board. There is no distinction between negative and positive electrodes. Connect the shield layer to the sheet metal of the electric control box, as shown in the following figure:

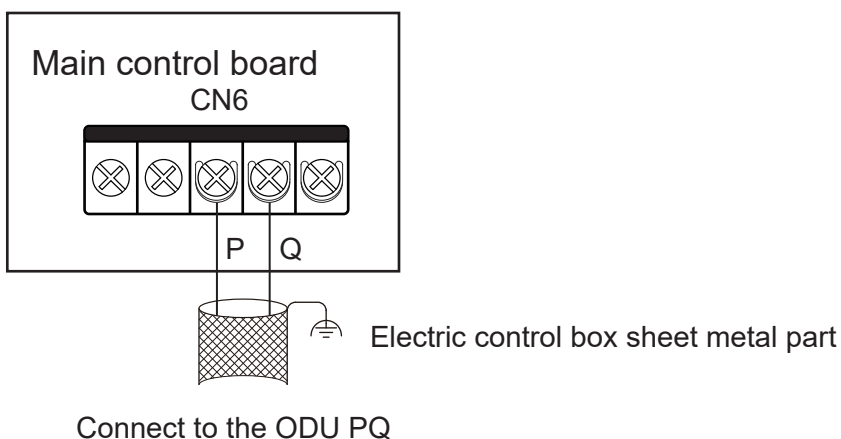

System: The maximum total length of the P/Q communication cable of the IDU and ODU can be up to 1200m, and can be connected in serial, as shown in the figure below:

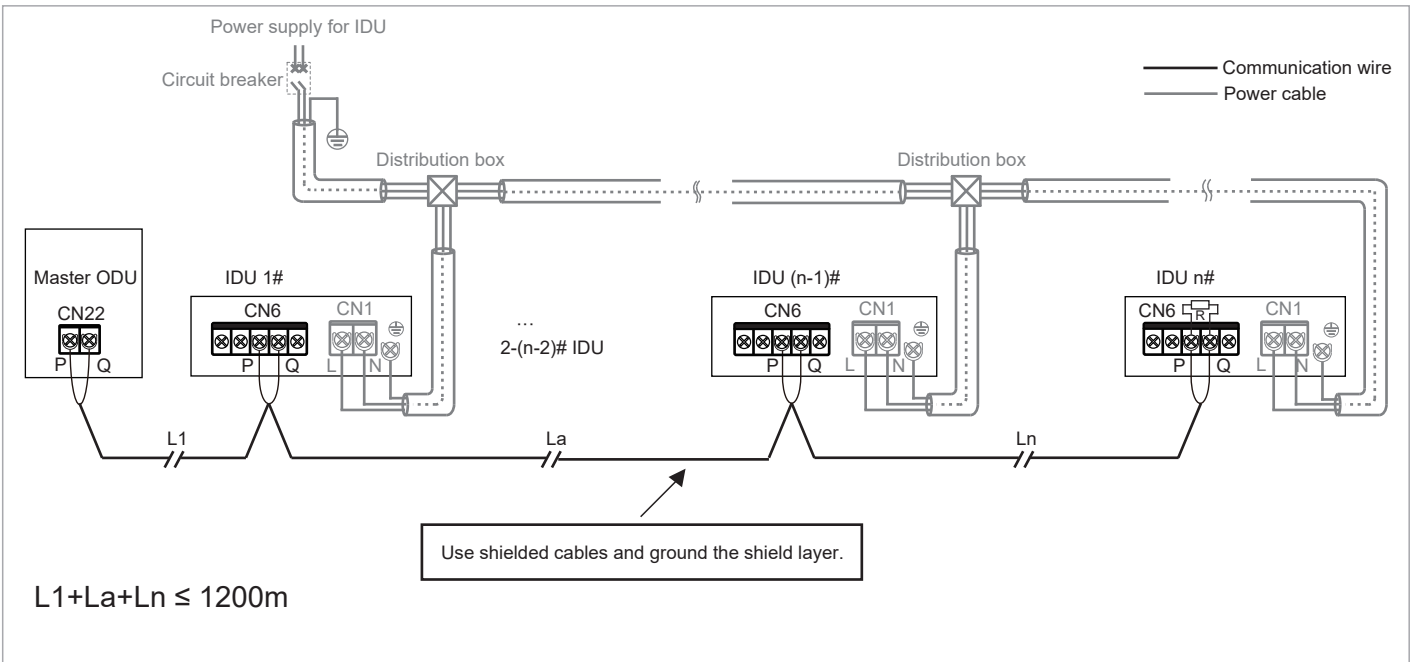

#### D P/Q/E communication

If some of the IDUs in the same refrigerant system are non-V8 series, it is required to connect "P", "Q", and "E" for P/Q/E communication.

Single unit: Use a shielded cable for the P/Q/E communication and properly ground the shield layer. P, Q, and E ports are located at terminal block "CN6" of the main control board. There is no distinction between negative and positive electrodes. Connect the shield layer to the sheet metal of the electric control box, as shown in the following figure:

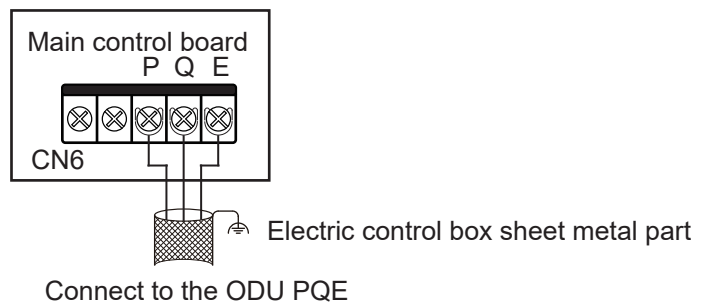

System: The maximum total length of the P/Q/E communication cable of the IDU and ODU can be up to 1200m, and can be connected in serial, as shown in the figure below:

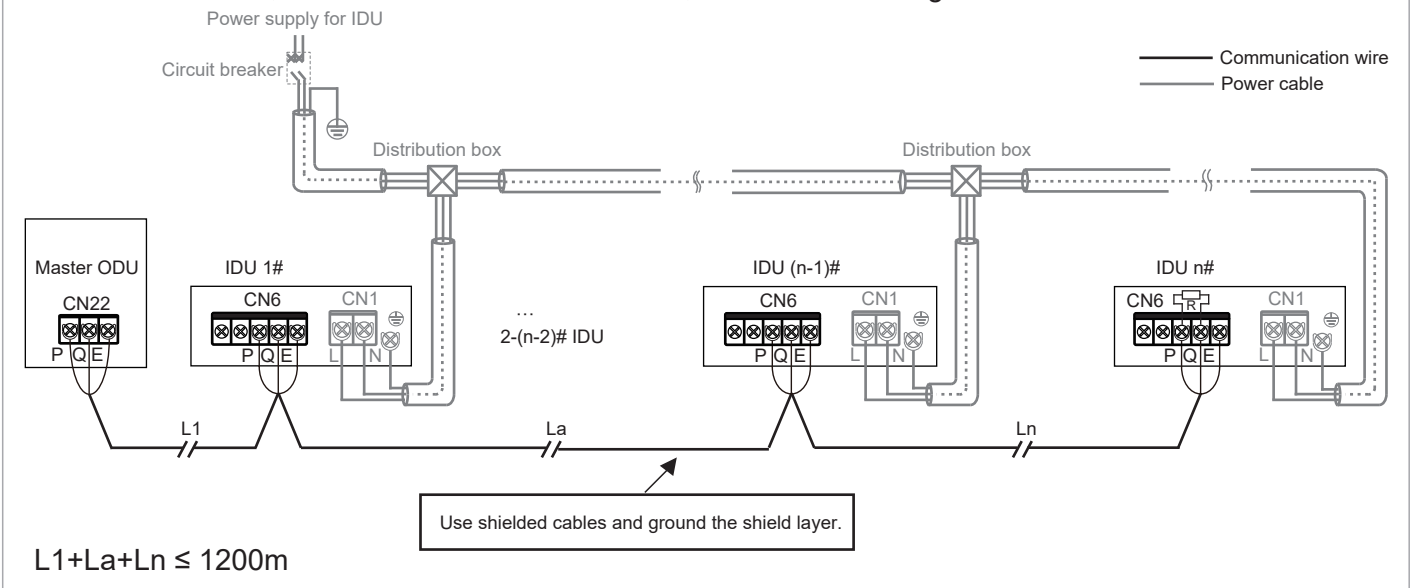

## [ Caution ]

When P/Q or P/Q/E communication is used, the IDUs need to be powered uniformly.

Either P/Q, P/Q/E communication or HyperLink communication can be selected. If it is required for IDUs to have independent power supplies, then HyperLink communication must be selected.

Use only shielded cables for P/Q or P/Q/E communication. Otherwise, the IDU and ODU communication may be affected.

A matching resistor needs to be added to the last IDU on the PQ (in the accessory bag of the ODU).

### ④ X1/X2 communication cable connection

The X1X2 communication line is mainly connected to the wired controller to achieve one controller per IDU and two controllers per IDU. The total length of the X1X2 communication line can reach 200 meters. Please use shielded wires, but the shield layer cannot be grounded. X1 and X2 ports are located at terminal block "CN6" of the main control board. There is no distinction between negative and positive electrodes. For details, see the following figure:

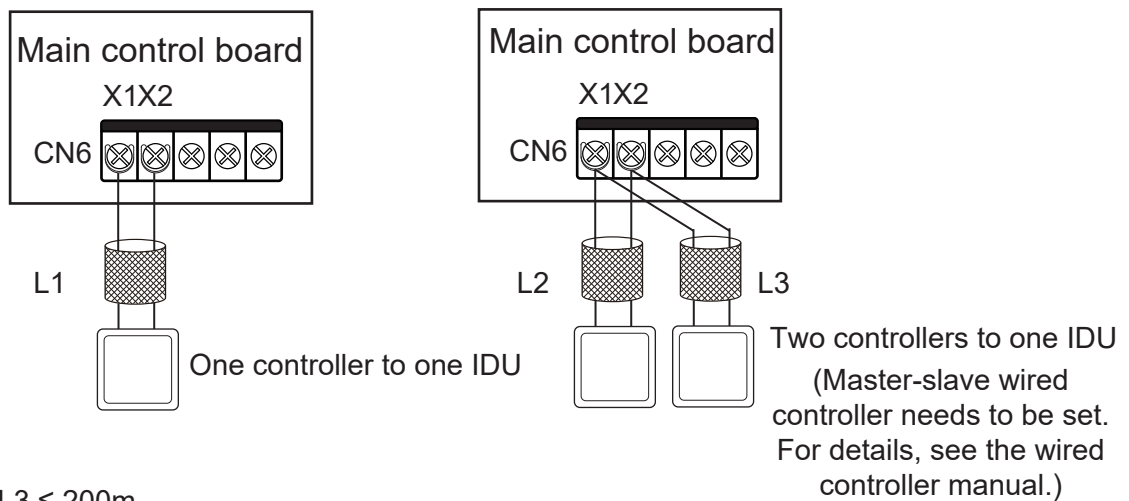

## [ Caution ]

Two wired controllers of the same model can be used to control one IDU at the same time. In this case, you need to set one controller to be the master and the other to be the slave. For details, see the wired controller manual.

⑤ D1D2 communication line connection (limited to ODU and system configuration)

**A** Achieving one-to-multiple and two-to-multiple functions of the IDU wired controller through D1D2 communication (a maximum of 16 sets)

D1D2 communication is 485 communication. The one-to-more and two-to-more functions of the IDU wired controller can be achieved through D1D2 communication, as shown in the figure below:

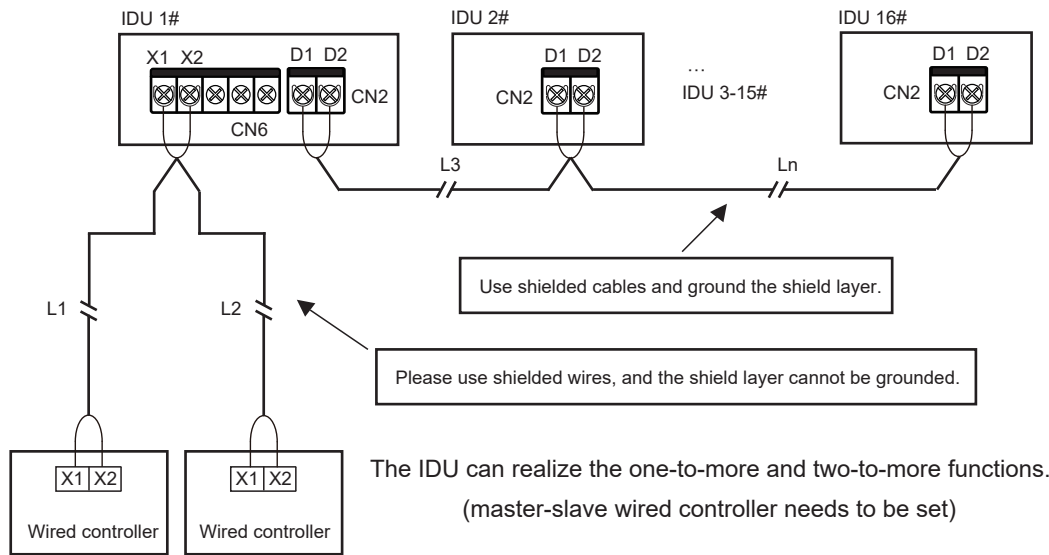

$$L1+L2 \leq 200m, L3+Ln \leq 1200m$$

**[ Caution ]**

When the IDUs in the same refrigerant system are V8 IDUs, D1D2 communication can enable one-to-multiple and two-to-multiple functions of the IDU wired controller.

To enable two-to-multiple functions, wired controllers must be of the same model.

**B** Achieving centralized control of the IDU through D1D2 communication

The D1D2 communication line can also be connected to the centralized controller to achieve centralized control of the IDU, as shown in the figure below:

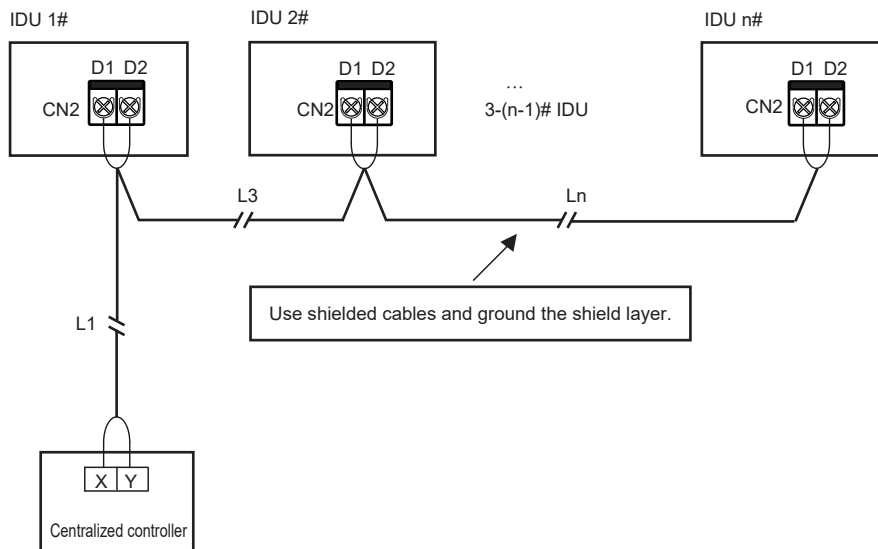

$$L1+L3+Ln \leq 1200m$$

## 5 External board connection (limited to ODU and system configuration)

The external board is a connection module outside the main control board, including a display box, function module adapter board, and optional function expansion boards 1 and 2.

### ① Connection of Display Box

The display box is connected to the main control board through a 4-core cable, and is connected to the "CN30" socket of the main control board, as shown in the following figure:

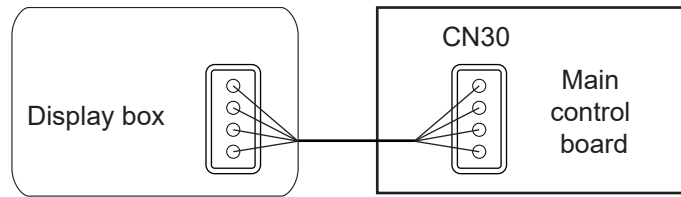

### ② Function module adapter board connection

Function expansion boards can communicate with the main control board through the adapter board. You can use one or both of the two function expansion boards. The wiring diagrams are as follows:

Use function expansion board 1#

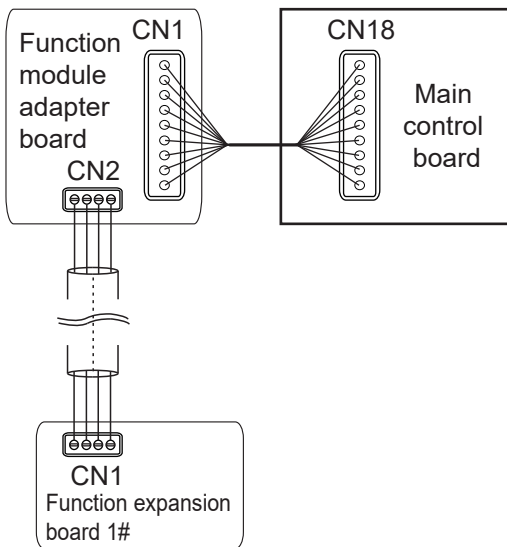

Use function expansion board 2#

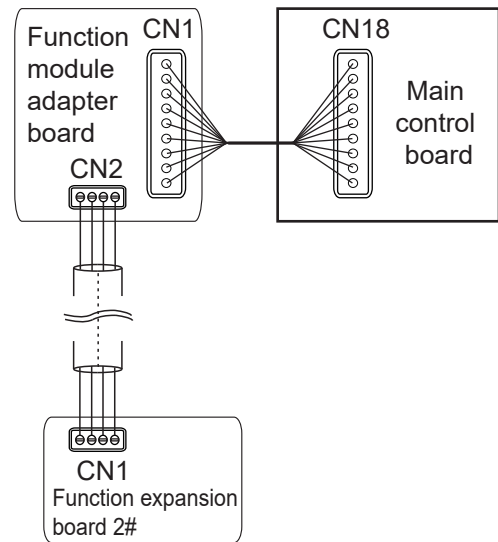

Use function expansion boards 1 and 2

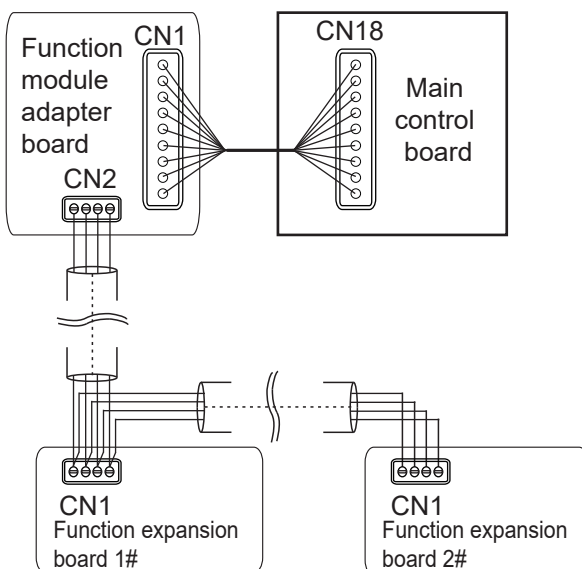

### [ Caution ]

For the function introduction of the function module adapter board, function expansion board 1#, and function expansion board 2#, please refer to the function module manual.

## 6 Reclose the electric control box cover

Straighten out the connecting wires and lay them flat, and close the electric control box cover again.

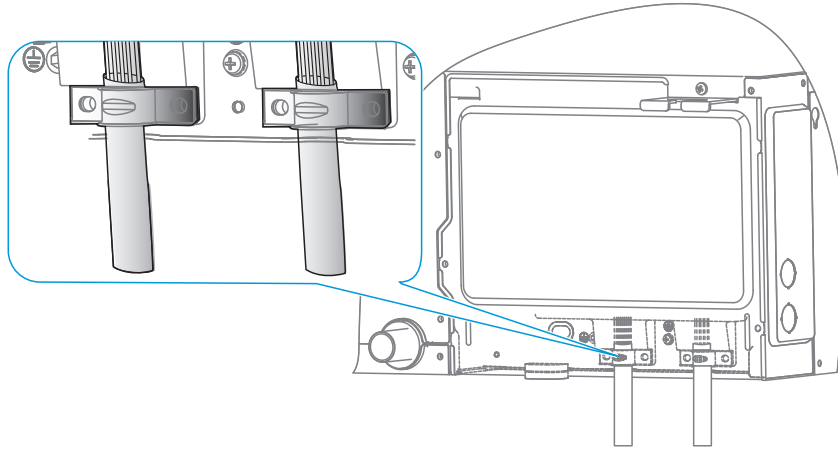

### [ Caution ]

Do not cover the electric control box during power-on.

When covering the electric control box, arrange the cables carefully and do not clip the connecting wires on the electric control box cover.





























# 9 Application Control

## Error Codes and Definitions

In the following circumstances (warning failures excluded), please stop the air conditioner immediately, cut off the power switch and contact the local air conditioner customer service center. The error code is displayed on the display box and the wired controller display.

Error	Error code	Digital display
Emergency stop	A01	
R32 refrigerant leaks, requiring shutdown immediately	A11	
ODU fault	A51	
The fault of the linked FAPU is transmitted to the master IDU (series setting)	A71	
The fault of the linked humidifying IDU is transmitted to the master IDU	A72	
The fault of the linked FAPU is transmitted to the master IDU (non-series setting)	A73	
The fault of the AHU Kit slave unit is sent to the master unit	A74	
Self-check fault	A81	
MS (refrigerant flow direction switching device) fault	A82	
Mode conflict (V6 communication protocol adopted)	A91	
1# EEV coil fault	b11	
1# EEV body fault	b12	
2# EEV coil fault	b13	
2# EEV body fault	b14	
Stall protection on 1# water pump	b34	
Stall protection on 2# water pump	b35	
Water level switch alarm	b36	
Reheating electric heater fault	b71	
Preprocessing electric heater fault	b72	
Humidifier fault	b81	
Duplicate IDU address code	C11	

Error	Error code	Digital display
Abnormal communication between the IDU and ODU	C21	
Abnormal communication between the IDU main control board and fan drive board	C41	
Abnormal communication between the IDU and wired controller	C51	
Abnormal communication between the IDU and Wi-Fi Kit	C52	
Abnormal communication between the IDU main control board and display board	C61	
Abnormal communication between the AHU Kit slave unit and master unit	C71	
Number of AHU Kits is not the same as the set number	C72	
Abnormal communication between the linked humidifying IDU and master IDU	C73	
Abnormal communication between the linked FAPU and master IDU (series setting)	C74	
Abnormal communication between the linked FAPU and master IDU (non-series setting)	C75	
Abnormal communication between the main wired controller and secondary wired controller	C76	
Abnormal communication between the IDU main control board and 1# function expansion board	C77	
Abnormal communication between the IDU main control board and 2# function expansion board	C78	
Abnormal communication between the IDU main control board and adapter board	C79	
Air inlet temperature of the IDU is too low in heating mode	d16	
Air inlet temperature of the IDU is too high in cooling mode	d17	
Alarm for exceeding temperature and humidity range	d81	
Sensor control board fault	dE1	
PM2.5 sensor fault	dE2	
CO2 sensor fault	dE3	
Formaldehyde sensor fault	dE4	
INTELLECTUAL EYE sensor fault	dE5	
T0 (fresh inlet air temperature sensor) short-circuits or cuts off	E21	
The upper dry bulb temperature sensor short-circuits or cuts off	E22	
The lower dry bulb temperature sensor short-circuits or cuts off	E23	
T1 (IDU return air temperature sensor) short-circuits or cuts off	E24	

Error	Error code	Digital display
The built-in room temperature sensor of the wired controller short-circuits or cuts off	E31	
The wireless temperature sensor short-circuits or cuts off	E32	
The external room temperature sensor short-circuits or cuts off	E33	
Tcp (pre-cooled fresh air temperature sensor) short-circuits or cuts off	E61	
Tph (pre-heated fresh air temperature sensor) short-circuits or cuts off	E62	
TA (outlet air temperature sensor) short-circuits or cuts off	E81	
Outlet air humidity sensor fault	EA1	
Return air humidity sensor fault	EA2	
Upper wet bulb sensor fault	EA3	
Lower wet bulb sensor fault	EA4	
R32 refrigerant leakage sensor fault	EC1	
T2A (heat exchanger inlet temperature sensor) short-circuits or cuts off	F01	
T2 (heat exchanger middle temperature sensor) short-circuits or cuts off	F11	
T2 (heat exchanger middle temperature sensor) overtemperature protection	F12	
T2B (heat exchanger outlet temperature sensor) short-circuits or cuts off	F21	
Main control board EEPROM fault	P71	
IDU display control board EEPROM fault	P72	
Locked (electronic lock)	U01	
Unit model code not set	U11	
Horsepower code not set	U12	
Horsepower code setting error	U14	
AHU Kit fan control input signal DIP setting error	U15	
Address code not detected	U38	
Motor failed more than once	J01	
IPM (fan module) overcurrent protection	J1E	
Instantaneous overcurrent protection for phase current	J11	

Error	Error code	Digital display
Low bus voltage fault	J3E	
High bus voltage fault	J31	
Phase current sample bias error	J43	
Motor and IDU are unmatched	J45	
IPM and IDU are unmatched	J47	
Motor startup failure	J5E	
Motor blocking protection	J52	
Speed control mode setting error	J55	
Phase lack protection of motor	J6E	

## Operating Status Codes and Definitions (Non-Error)

Definition	Code	Digital display
Oil return or preheating operation	d0	
Self-cleaning	dC	
Mode conflict (V8 communication protocol adopted)	dd	
Defrosting	dF	
Static pressure detection	d51	
Remote shutdown	d61	
IDU backup operation	d71	
ODU backup operation	d72	
Main control program upgrading	OTA	

### [ Caution ]

Error codes are displayed only for certain ODU models and IDU configurations (including the wired controller and display box).

When the main control program is being upgraded, make sure that the IDU and ODU remain powered on. Otherwise, the upgrading process will stop.

## Spot Check Description

Use the bi-directional communication wired controller (for example, WDC3-86S) to activate the spot check function in the following steps:

- ① On the main page, hold "☰" and "▲" for 2s to enter the query page. The wired controller displays "CC". Press "▲" or "▼" key to select the IDU address n00-n63 (indicating the address of a specific IDU), and press the "↵" key to enter the parameter query page.
- ② Press the "▲" or "▼" key to query the parameters, and the parameters can be queried cyclically. See the spot check list below for details.
- ③ Press the "⌚" key to exit the query function.
- ④ On the top of the query page, the "Timing area" displays the spot check serial number, and the "Temperature area" displays the content of the spot check parameters.

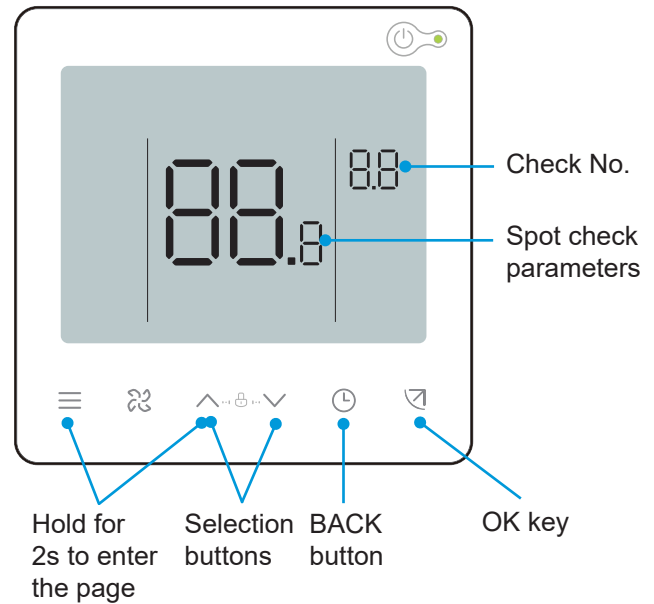

No.	Displayed content	No.	Displayed content
1	IDU and ODU communication address (current IDU addresses are displayed every 0.5s)	13	Compressor discharge temperature
2	Capacity HP of IDU	14	Target overheating
3	Actual set temperature Ts	15	EEV opening (actual opening/8)
4	Current running set temperature Ts	16	Software version No.
5	Actual T1 indoor temperature	17	Display board version No.
6	Modified indoor temperature T1_modify	18	Fan drive version No.
7	T2 heat exchanger intermediate temperature	19	Historical error code (recent)
8	T2A heat exchanger liquid pipe temperature	20	Historical error code (sub-recent)
9	T2B heat exchanger gas pipe temperature	21	IDU network address display
10	Actual set humidity RHs	22	IDU expansion board address display
11	Actual RH indoor humidity	23	[— — —] is displayed
12	Real-time static pressure		

## ESP Setting

Use the bi-directional communication wired controller (for example, WDC3-86S) to set the unit external static pressure, which can be divided into the following two situations:

### 1 Constant Air Flow Mode

IDUs that are equipped with a constant air flow function are set to the constant air flow mode when they leave the factory. After the units are installed, they should undergo initial static pressure test before use. The steps are as follows:

- ① On the main page, hold "≡" and "↵" for 3s. The wired controller displays "CC". Press the "▲" or "▼" key to select the IDU address n00-n63 (indicating the address of a specific IDU), and press the "↵" key to enter the parameter setting page. The wired controller displays "n00".
- ② On the parameter setting page, press the "▲" and "▼" keys to switch the "Parameter code" to the initial static pressure detection code "n58", press "↵" key to enter the specific parameter setting, and then press "▲" and "▼" to set the parameter value to "01". Then, press the "↵" key to save the settings. Then the wired controller will send the initial static pressure detection command to IDUs. Wait a few minutes for the IDU to complete the initial static pressure detection.
- ③ Press "⌚" to return to the previous page until exiting the parameter settings or perform no operations for 60s and the system will automatically exit the parameter settings.

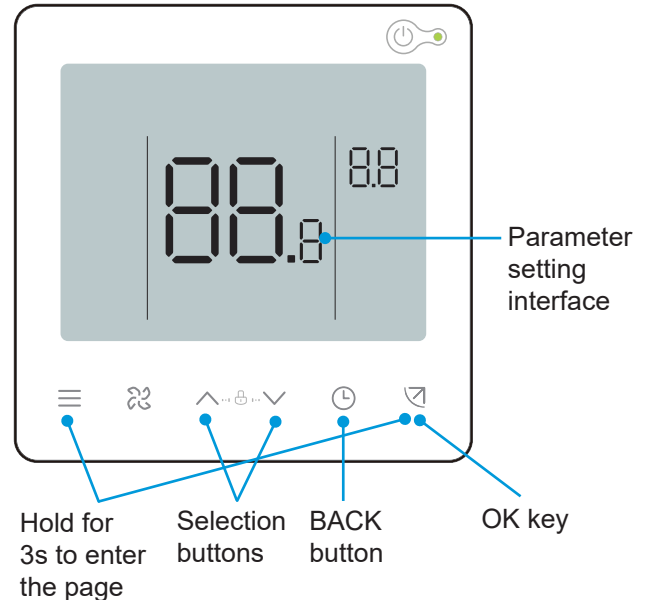

Parameter code	Parameter name	Parameter range	Default value	Remarks
n58	Initial static pressure detection	00/01	00	00: Not reset; 01: Reset

# Air Pressure Curve

## Constant air flow - self-adaptive

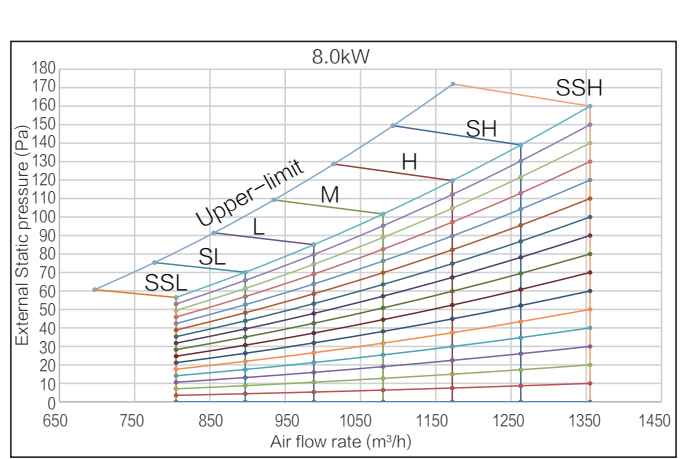
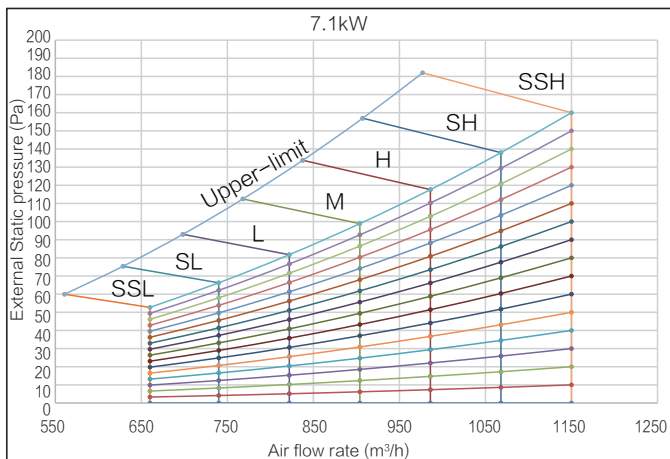
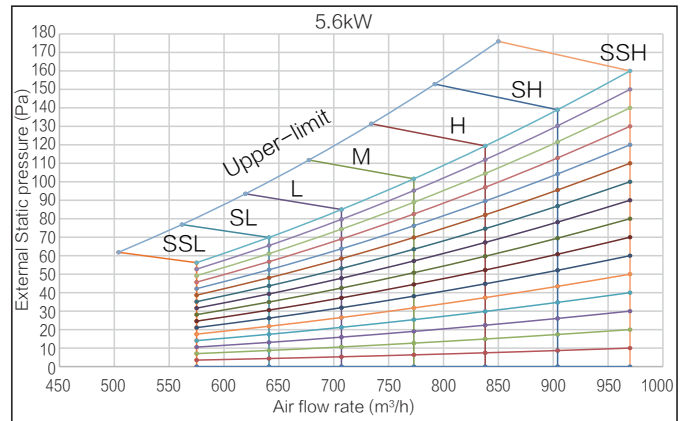
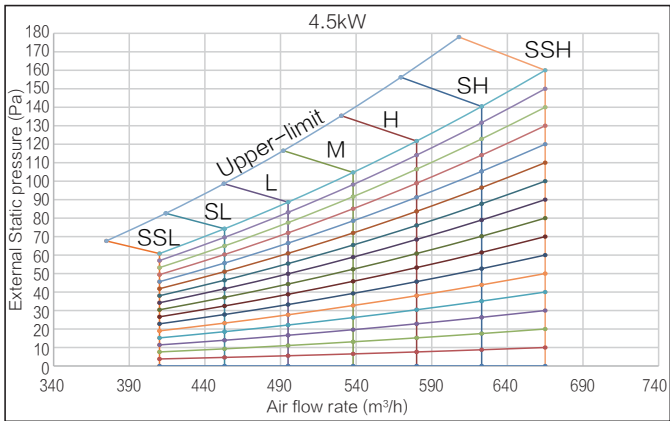
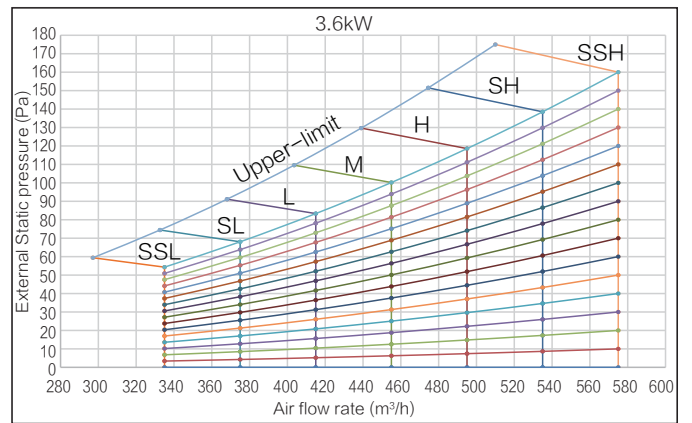
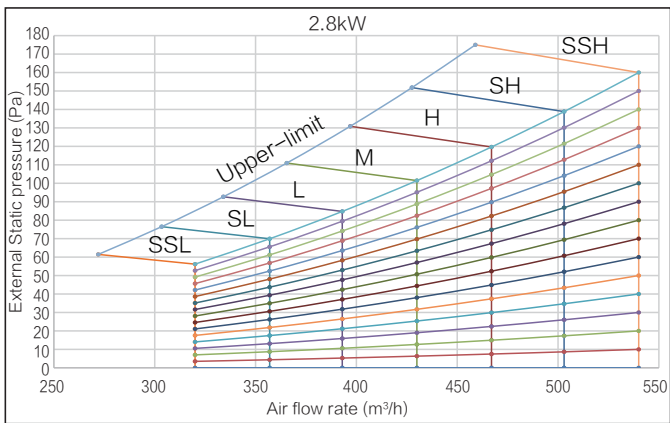
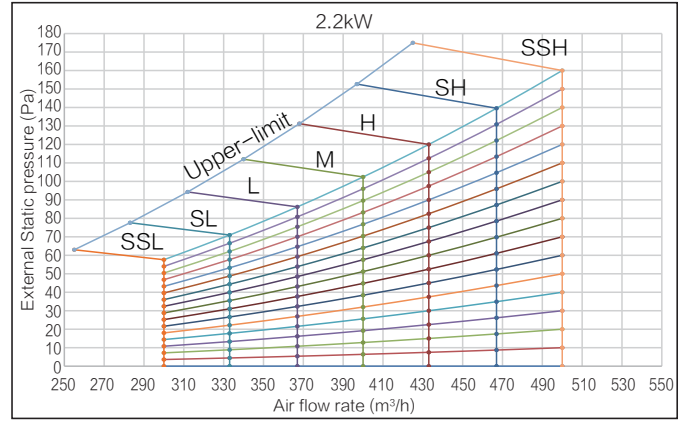
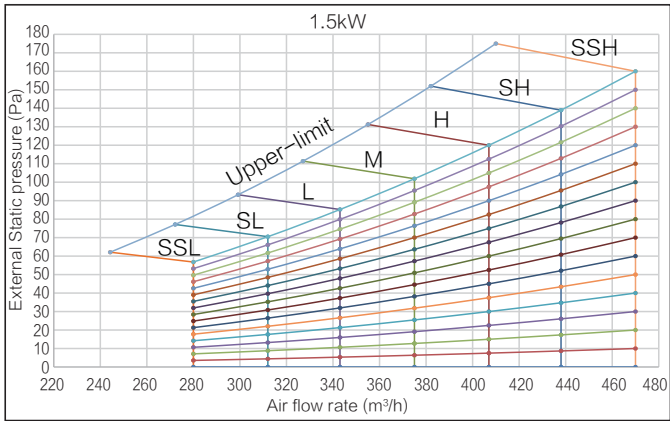

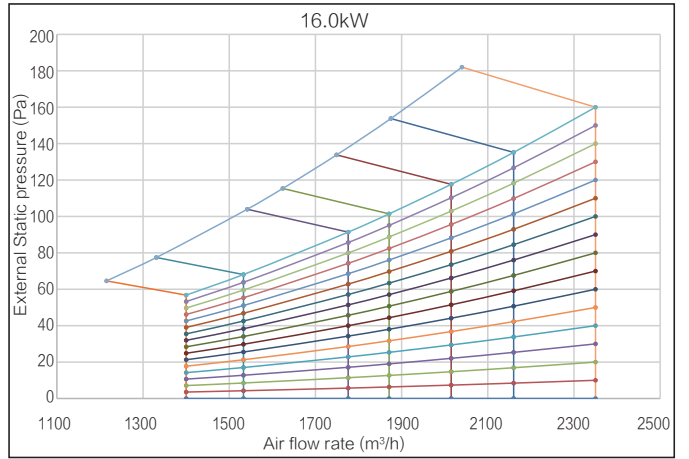
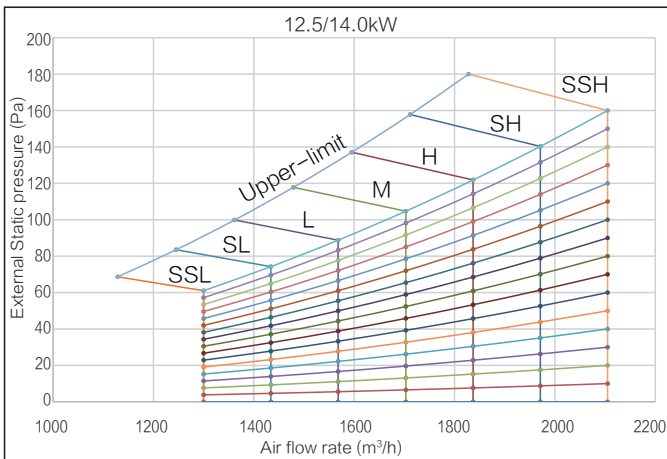
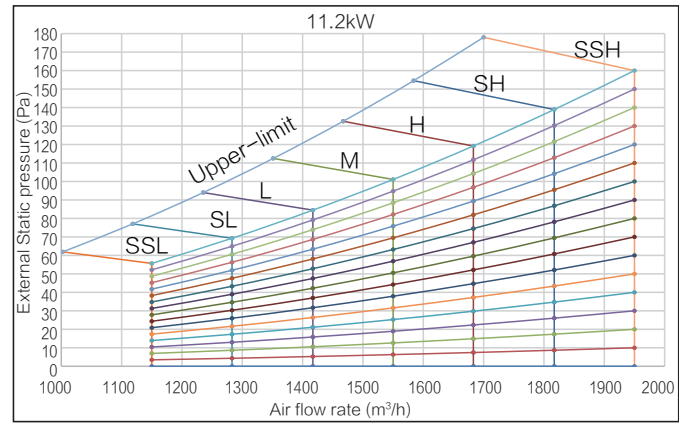
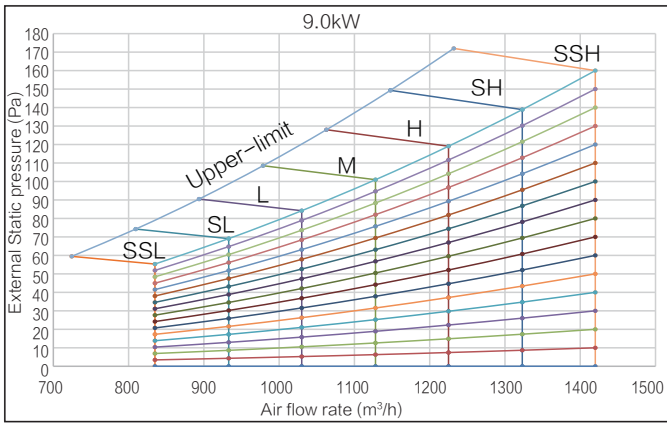

 [ Caution ]

The static pressure of the air duct should be taken into consideration when installing the unit. This model is not recommended if exceeding the specified static pressure range.

SSL, SL, L, M, H, SH, and SSH represent fan speeds from level 1 to level 7.



## 2 Constant speed mode

The bi-directional communication wired controller must be used to set the unit's external static pressure parameters to overcome the air outlet resistance. The steps are as follows:

- ① On the main page, hold "☰" and "↵" for 3s. The wired controller displays "CC". Press the "▲" or "▼" key to select the IDU address n00-n63 (indicating the address of a specific IDU), and press the "↵" key to enter the parameter setting page. The wired controller displays "n00".
- ② On the parameter setting page, the wired controller displays "n00". Press the "↵" key to enter the specific parameter setting, and then press "▲" and "▼" to adjust the parameter value of the unit external static pressure. Then, press the "↵" key to save the parameters. The unit external static pressure parameter has now been set.
- ③ Press "⌚" to return to the previous page until exiting the parameter settings or perform no operations for 60s and the system will automatically exit the parameter settings.

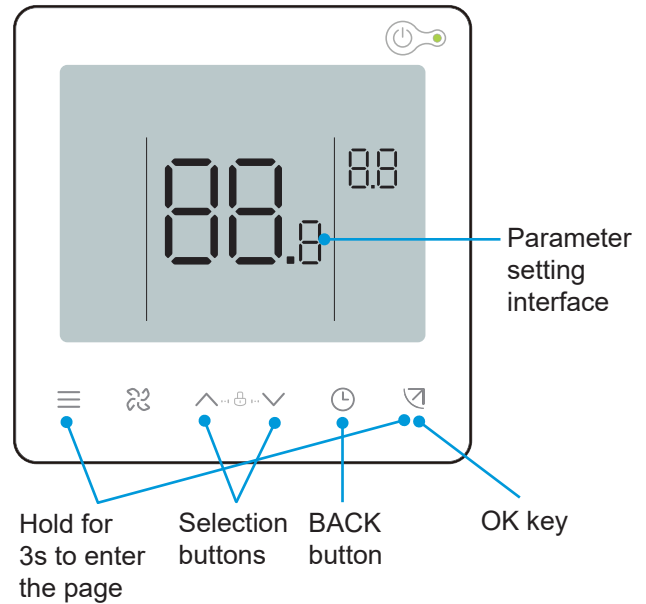

Parameter code	Parameter name	Parameter range	Default value	Remarks
n00	Unit external static pressure	Unit external static pressure stop: 02/04/06/07/08/09/~ /19	1.5-7.1kW: 06 8.0-11.2kW: 07 12.5-16.0kW: 08	Set the corresponding static pressure value FF of the IDU according to the IDU speed

Static pressure setting parameter table

Unit power	Static pressure settings															
	Level 02	Level 04	Level 06	Level 07	Level 08	Level 09	Level 10	Level 11	Level 12	Level 13	Level 14	Level 15	Level 16	Level 17	Level 18	Level 19
W*100	Pa	Pa	Pa	Pa	Pa	Pa	Pa	Pa	Pa	Pa	Pa	Pa	Pa	Pa	Pa	Pa
HP	Pa	Pa	Pa	Pa	Pa	Pa	Pa	Pa	Pa	Pa	Pa	Pa	Pa	Pa	Pa	Pa
15 (0.6HP)																
22 (0.8HP)																
28 (1.0HP)																
36 (1.2HP)																
45 (1.7HP)																
56 (2.0HP)																
71 (2.5HP)	10	20	30	40	50	60	70	80	90	100	110	120	130	140	150	160
80 (3.0HP)																
90 (3.2HP)																
112 (4.0HP)																
125 (4.6HP)																
140 (5.0HP)																
160 (5.7HP)																

# Air Pressure Curve

Constant speed

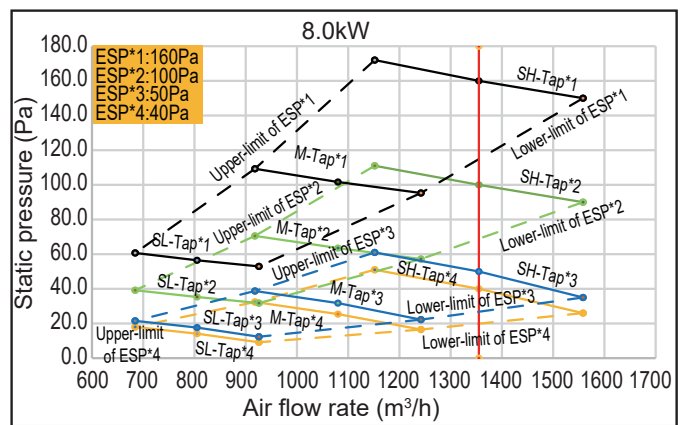
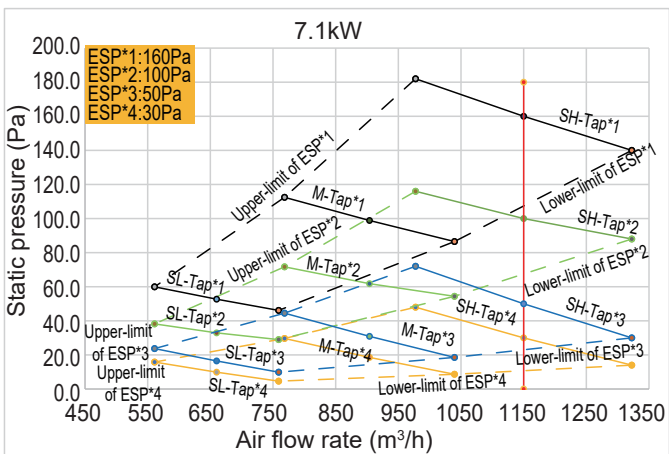
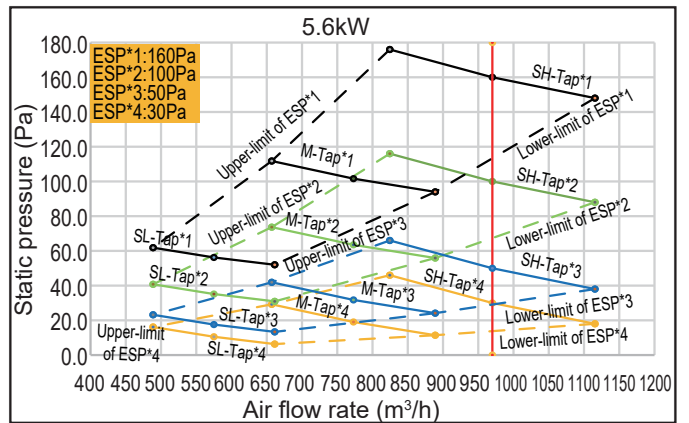
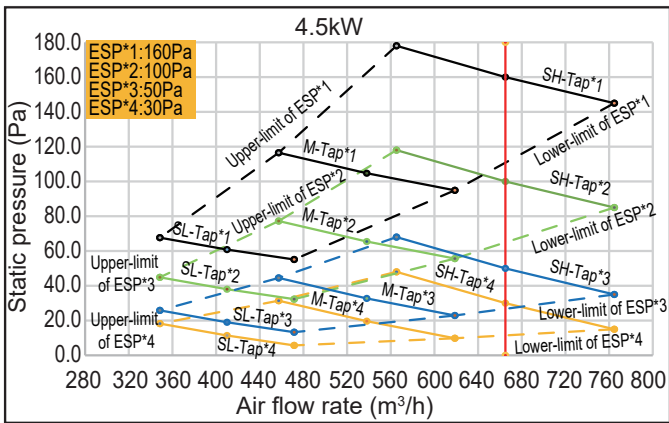
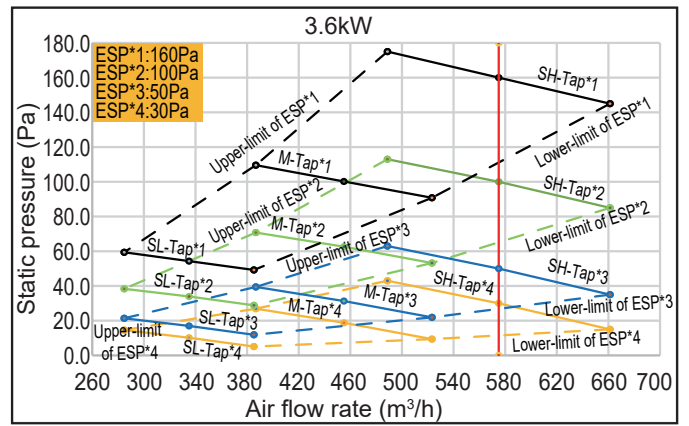
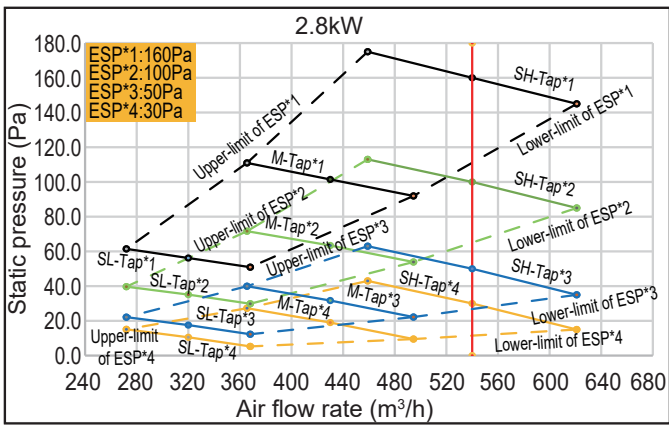
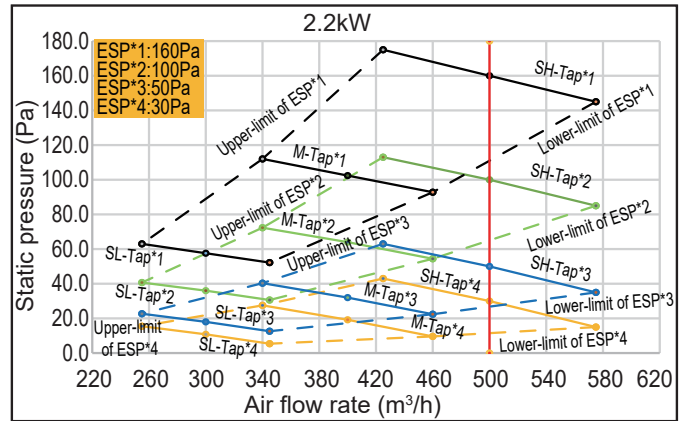
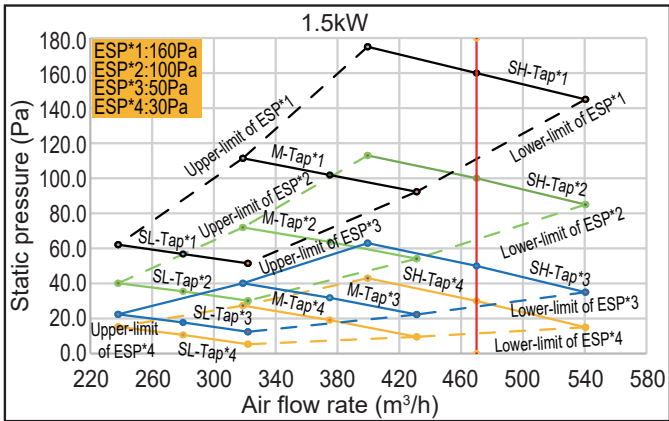

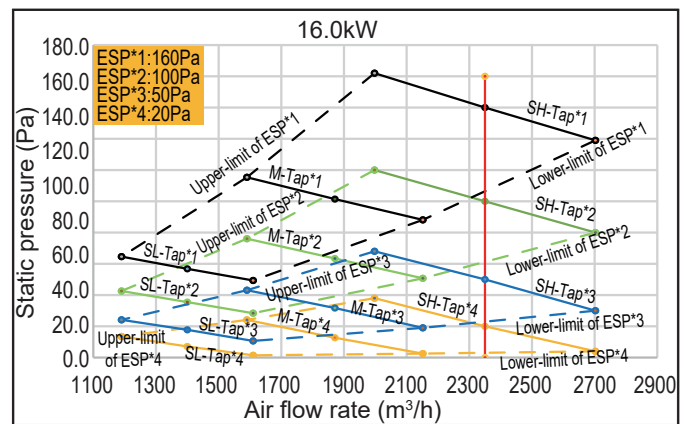
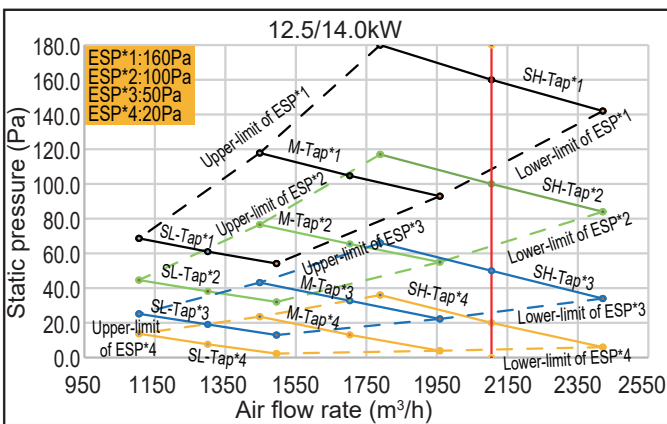
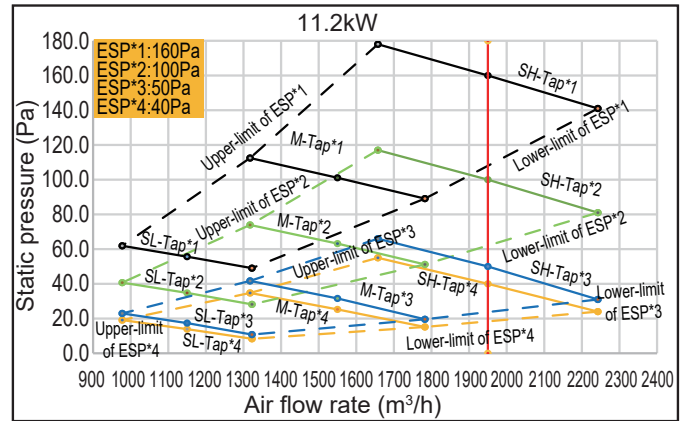
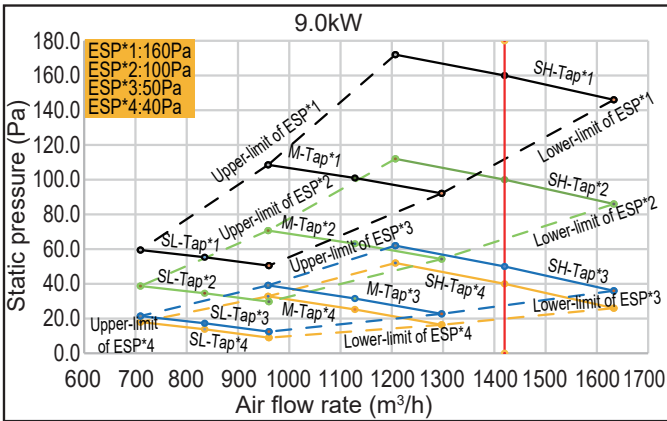

### 3 Switch between Constant Air Flow and Constant Speed

The two operating modes are switched as follows:

- ① On the main page, hold "≡" and "↵" for 3s. The wired controller displays "CC". Press the "▲" or "▼" key to select the IDU address n00-n63 (indicating the address of a specific IDU), and press the "↵" key to enter the parameter setting page. The wired controller displays "n00".
- ② On the parameter setting page, press the "▲" and "▼" keys to switch the "Parameter code" to the constant air flow setting parameter code "n30", press the "↵" key to enter the specific parameter setting, and then press "▲" and "▼" to adjust the parameter value of the operating mode. Then, press the "↵" key to save the parameters. The operating mode parameter has now been set.
- ③ Press "⌚" to return to the previous page until exiting the parameter settings or perform no operations for 60s and the system will automatically exit the parameter settings.

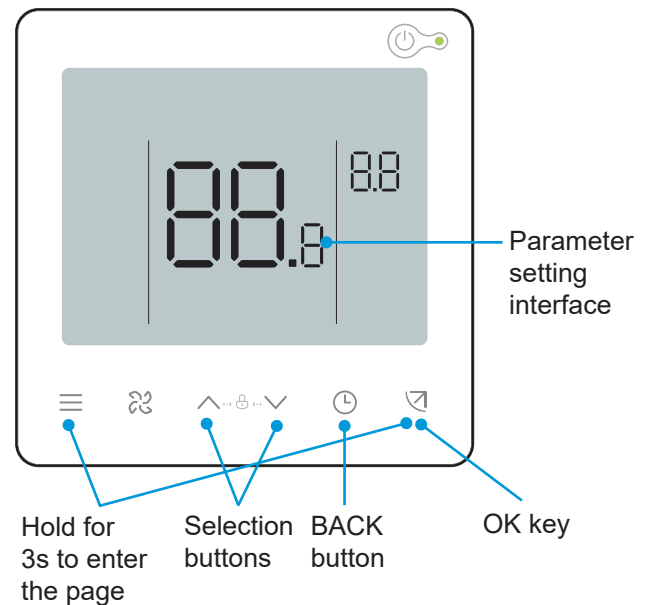

Parameter code	Parameter name	Parameter range	Default value	Remarks
n30	Constant air flow setting	00/01	01	00: Constant speed; 01: Constant air flow

## [ Caution ]

Parameters can be set while the unit is powered on or powered off.

On the parameter setting page, the wired controller does not respond to a remote signal, and does not respond to the app remote control signal.

When it is in the parameter settings page, the mode, fan speed, and switch buttons are invalid.

Please refer to the remote controller manual for the setting parameters of the remote controller.

For other IDU parameter settings, please refer to the manual of the wired controller.

# 10 Test Run

## Before the Test Run, Make Sure That

- IDUs and the ODU are properly installed.
- The piping is correct, and the refrigerant piping system has been checked for leakage.
- Piping length and the amount of refrigerant charged have been recorded.
- The wiring is correct and firm without virtual connection issues. Ground wires have been properly connected.
- The voltage of the power supply is the same as the rated voltage of the air conditioner.
- Heat insulation is complete.
- There are no obstructions at the air inlet and outlet of the IDU and ODU.
- Fully open the check valves of the gas pipe and liquid pipe of the ODU.
- Turn on the power supply to preheat the ODU for 12 hours.

## Test Run

In the event of a failure, please troubleshoot according to the "Symptoms That Are Not Faults" in the "Precautions for Use" in this manual.

## IDU

- The wired/remote controller switch is operating normally.
- The display of the wired/remote controller is normal, the function keys work normally, the room temperature adjustment is normal, and the air flow and direction adjustment are normal.
- The LED indicator is on.
- Water discharge is normal.
- Check the IDUs one by one for normal operation, and the cooling and heating functions are normal without vibration or abnormal sound.

- There are no vibrations or strange sounds during operation.
- The fan, noise and condensation do not affect the neighbors.
- There is no refrigerant leakage.

## Inspection After Installation

To ensure a comfortable indoor environment, please run down through the list to check whether the installation of the air conditioner meets the requirements. Insert a "x" for Fail and a "√" for Pass.

Check Item	Check Criteria	Check Result (Pass/Fail)
Are the IDUs and ODUs securely installed?	The air conditioner does not fall or vibrate, and there is no noise.	
Has the installation of the IDU been completed?	The unit works properly and no parts are burned out.	
Has a leak test been performed?	The cold/hot air is sufficient.	
Is the heat insulation in good condition (refrigerant piping, drainage pipe, and air ducts)?	There is no condensation dripping.	
Were the copper pipes sealed before installation to prevent dust from entering?	The compressor is functional.	
Is the refrigerant piping filled with nitrogen for shielded welding during the welding process (a nitrogen cylinder is on site)?	There is no oxide film on the inner surface of the copper pipe. The system is functional with no major failures.	
Has a water discharge test been performed? Is drainage smooth? Is the connection secure?	There is no water leakage.	
Is the power supply voltage consistent with the specified voltage on the unit nameplate?	The unit works properly and no parts are burned out.	
Are the wires and pipes connected correctly?	The unit works properly and no parts are burned out.	
Is the air conditioner safely grounded?	There is no electric leakage.	
Have wires of the specified size been used?	The unit works properly and no parts are burned out.	
Are the terminal screws securely fastened?	There is no electric shock or fire.	
Are the inlets and outlets of the IDUs and ODUs free of obstruction?	The cold/hot air is sufficient.	
Has the unit's external static pressure been set for the IDU in constant speed mode?	The cooling and heating functions are normal.	
Has the refrigerant piping length and refrigerant charge been recorded?	The amount of refrigerant in the air conditioning system is clear.	
Was an access hole reserved at the installation position of the IDU?	The maintenance can be easily carried out.	
Are air filters and grilles installed (at air inlets and outlets)?	The unit works properly.	
Does the temperature of each room meet the requirements during testing?	Users' comfort needs can be satisfied.	
Have you explained to the user how to operate the unit according to the user manual?	The unit is effective.	
Have you explained to the user how to operate and clean the air filter, grille (air inlets and outlets), etc.?	The unit is effective.	

# Cleaning, Maintenance and After-Sales Service

## 1 Safety Warning

### [ Warning ]

For safety reasons, always turn off the air conditioner and turn off the power before cleaning the air conditioner.

Do not disassemble or repair the air conditioner by yourself; otherwise, it may cause fire or other hazards.

Only professional service personnel can carry out the maintenance.

Do not use flammable or explosive materials (such as hair styling agents or pesticides) near the product.

Do not use organic solvents such as paint thinner to clean this product; otherwise, it may cause cracks, electric shock or fire.

Only qualified dealers and professionally qualified electricians can install the optional accessories.

Be sure to use the optional accessories specified by our company.

Improper installation by yourself may result in water leakage, electric shock or fire.

Do not wash the air conditioner with water; otherwise, it may cause an electric shock.

Use a stable standing platform.

## 2 Cleaning and Maintenance

### Cleaning the Air Filter

#### [ Caution ]

Air filters are optional.

Air filters can be used to remove dust or other particles from the air, and if clogged, the effectiveness of the air conditioner will be greatly reduced.

Therefore, be sure to clean the air filter frequently when using it for an extended period.

For the IDU with constant speed mode, if it is installed in a place with a lot of dust, it is recommended that you clean the filter once a month. For IDUs with a constant air flow mode, clean the filter when you receive the reminder of the wired controller.

If excess dirt makes the filter difficult to clean, replace the filter.

Do not remove the air filter unless it is being cleaned; otherwise, it may cause malfunction.

# 1 Procedure diagram

- ① Remove the air inlet grille.  
For duct type air conditioners, open the air inlet grille as shown in the figure.

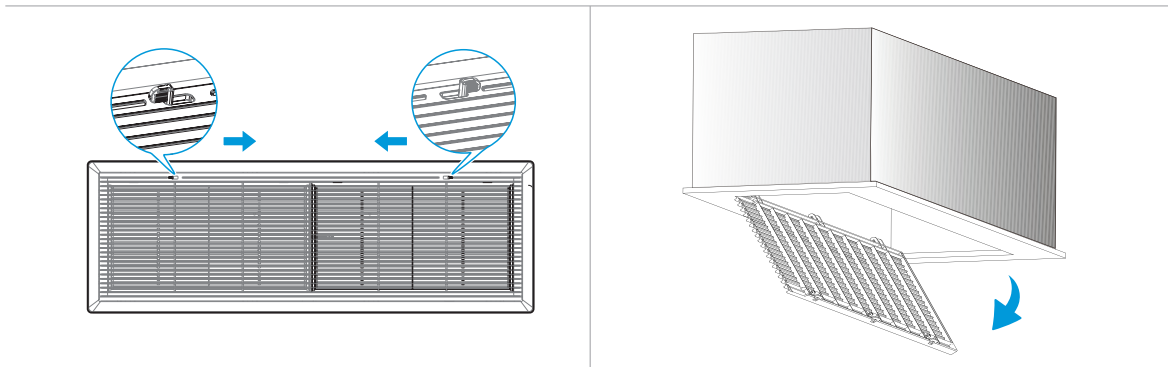

- ② Remove the filter.

## 💡 [ Note ]

Only professionals can change and disassemble the filter. Any improper operations may cause electric shock or injuries due to touching rotating parts.

- ③ Clean the filter.

Clean the filter with a vacuum cleaner, with the air inlet side of the filter facing upwards.

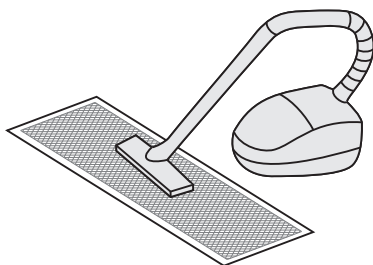

Clean the filter with clean water (except for the activated carbon module), with the air inlet side of the filter facing downwards.

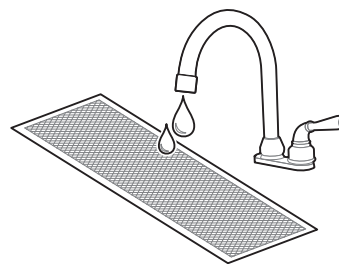

## ⚠ [ Caution ]

To avoid deformation of the filter, do not use fire or a burning appliance to dry the filter.

If the filter is heavily soiled, use a soft brush and neutral detergent to clean it, then shake off the water and dry it in a cool place.

Non-professionals should not disassemble, replace or repair the filter.

- ④ Reinstall the filter.

- ⑤ Reinstall and close the air inlet grille by following steps 1 and 2 above in reverse.

## Cleaning Air Outlets and Exterior Panels

- ① Wipe the air outlet and panel with a dry cloth.
- ② If a stain is hard to remove, clean it with clean water or neutral detergent.

### [ Caution ]

Do not use gasoline, benzene, volatile agents, decontamination powder or liquid insecticides. Otherwise, the air outlet or panel may become discolored or deformed.

Do not expose the inside of the IDU to moisture, as it may result in electric shock or fire.

When cleaning the louver with water, do not scrub it violently.

If the air conditioner is used without an air filter, the accumulation of dust in the air conditioner will often cause malfunctions due to the failure to remove dust from the indoor air.

## Maintenance

**During in-depth maintenance, the air conditioner should be cleaned and maintained by professional technicians every 2 to 3 years.**

**For the IDU in constant speed mode, the primary efficiency filter is usually cleaned every three months.**

When operating in a dusty environment, the air flow and capacity of the filter will decrease. The filter may even become blocked, and the air conditioner performance and indoor air compromised.

### **Preheat the unit in advance.**

When the heating season comes, power on the ODU master unit for preheating more than 4 hours before use. The preheating time depends on the weather temperature. This can make the air conditioner operate more stably and help the refrigeration oil in the air conditioner compressor to maintain the best lubrication state, which can prolong the service life of the compressor.

### **Complete the following steps before the air conditioner is put out of use for a long period:**

- ① If the air conditioner is not in use for a long time due to seasonal changes, keep the unit running for 4-5 hours in fan mode until the unit becomes completely dry. Otherwise, it may grow mold indoors and have negative health effects.
- ② When not in use for a long time, power off or unplug the power plug to reduce standby power consumption, and wipe the wireless remote controller with a clean soft dry cloth and remove the battery.
- ③ Turn on the power switch 12 hours before using the air conditioner again. In addition, in seasons when air conditioners are frequently used, keep the power switch on. Otherwise, failures may occur.

### [ Caution ]

Before the air conditioner is idle for a long time, the internal components of the ODUs should be checked and cleaned regularly. For more details, please contact the local air conditioner customer service center or special technical service department.

Check the return air inlet and outlet of the ODU and IDU after long periods of use to see if they are blocked; if an inlet/outlet is blocked, clean it immediately.



# 3 Maintenance of Conventional Parts

## Steps to dismantle the drain pan

The drain pan must first be removed during the maintenance of the internal unit assembly. Dismantle the drain pan according to the following schematic to prevent water leakage in the unit (Make sure there is no residual water in the drain pan before you dismantle it).

1 Dismantle the top cover plate assembly

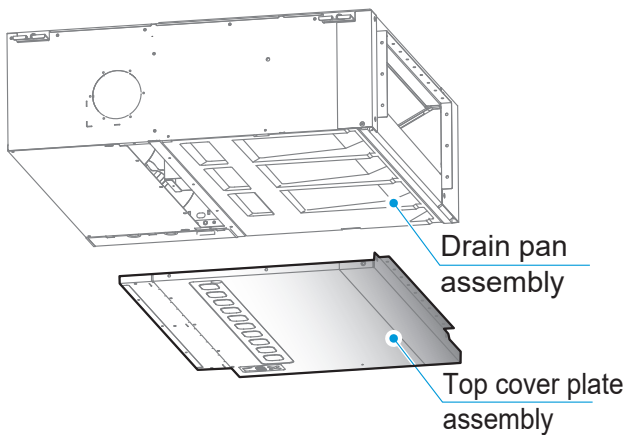

2 Remove the drain pan assembly in a downward direction

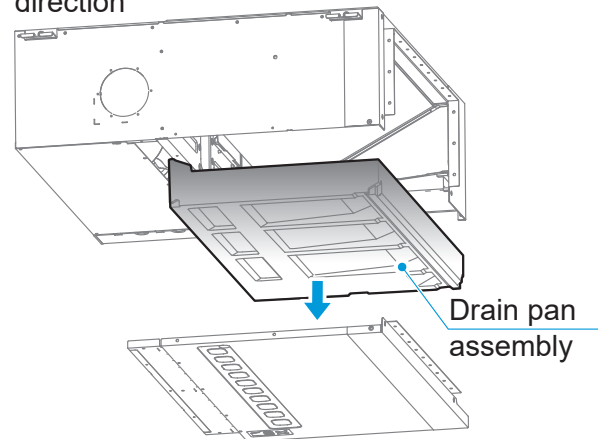

## Maintenance of propeller housing

1 Remove the return air cover  
(The bottom air return model is used as an example here. First, remove the filter if any.)

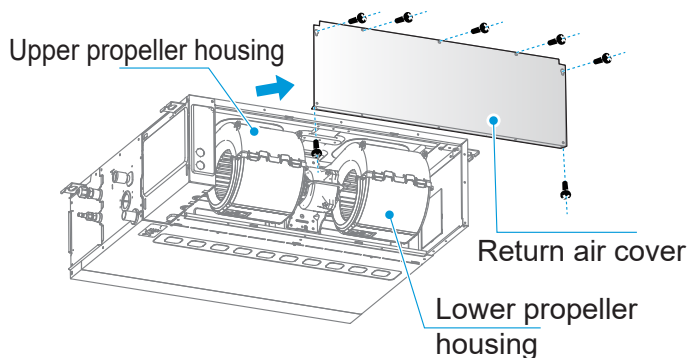

2 Remove the two screws from the top cover and rotate the portion of the top cover that covers the propeller housing by approximately 30 degrees around the long U-shaped hole, as shown in the figure.

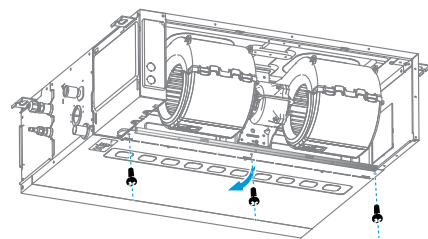

3 Remove the lower propeller housing in a downward diagonal direction.

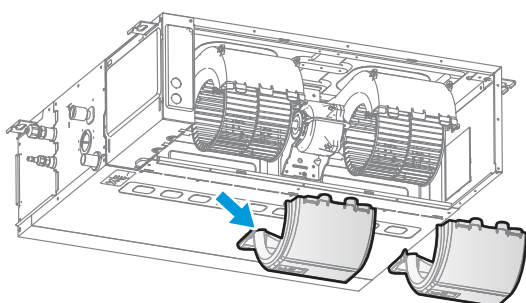

4 Loosen the screws on the upper propeller housing.

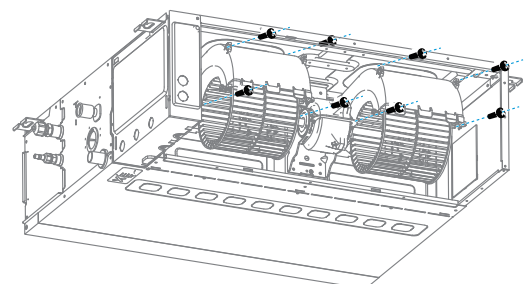

5 Move the upper propeller housing 50mm backward.

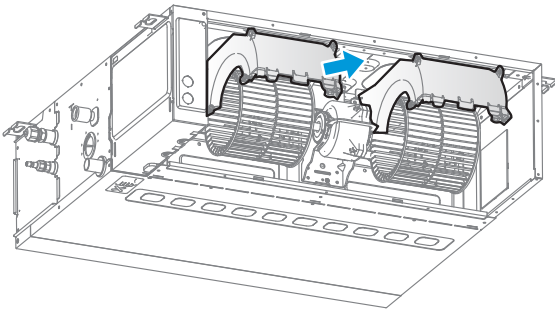

6 Make the propeller housing rotate more than 90° downward along the wind wheel.

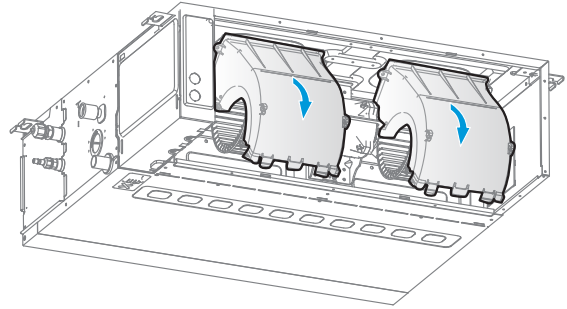

7 Remove the lower propeller housing in a backward direction.

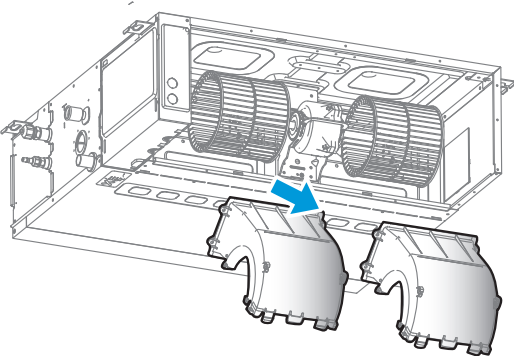

8 Note: Installation notes are as follows: The slot and latch bolt, and the limiting groove and side wall edge should be aligned first, and then be fastened; Check whether the limiting groove, positioning rod and buckle are installed in place, and the limiting latch bolt shall enclose the outside of the propeller housing.

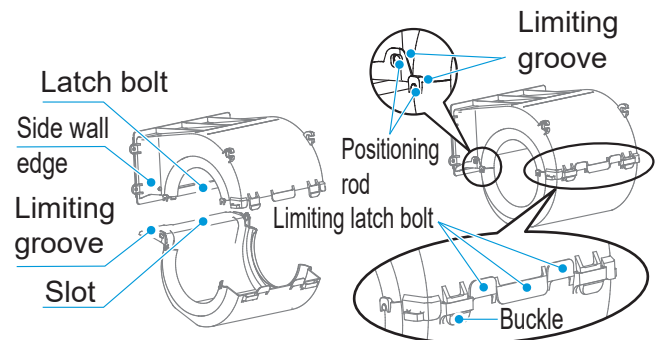

## 💡 [ Note ]

The first step of the rear air return model maintenance is to remove the return air cover in a downward direction. The other steps should be consistent.

## Maintenance of motor and wind wheel

1 Remove the two screws of the top cover assembly.

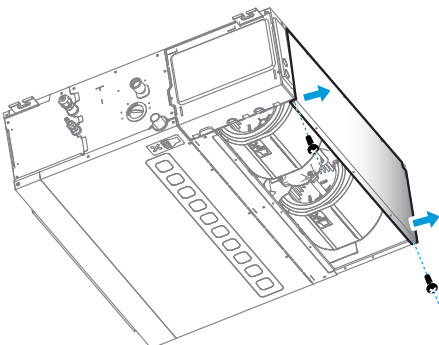

2 Rotate the portion of the top cover that covers the propeller housing by approximately 30 degrees around the long U-shaped hole, as shown in the figure.

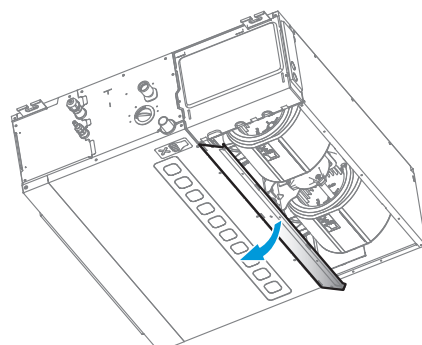

- 3** Press the buckle of the upper propeller housing, and rotate the lower propeller housing around the front edge of the lower propeller housing by about 30 degrees.

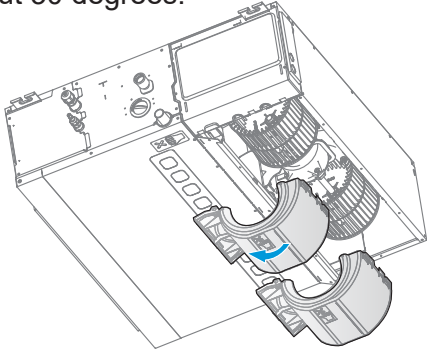

- 4** Loosen the fastening screws for the motor sealing plate and wind wheel.

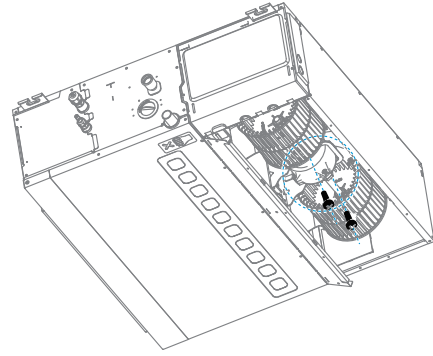

- 5** Remove the motor and wind wheel together.

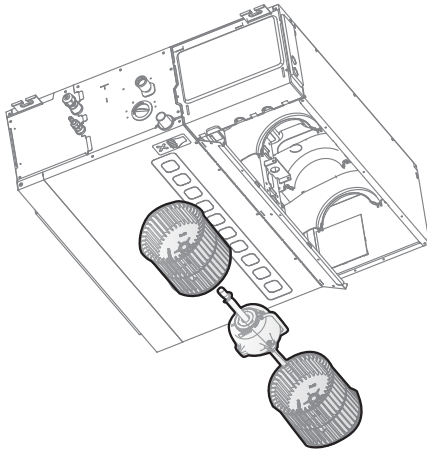

## Maintenance of the drain pump (with water pump), temperature sensor and electronic expansion valve

- 1** Remove the electric control box cover and unplug the pump and water level switch.

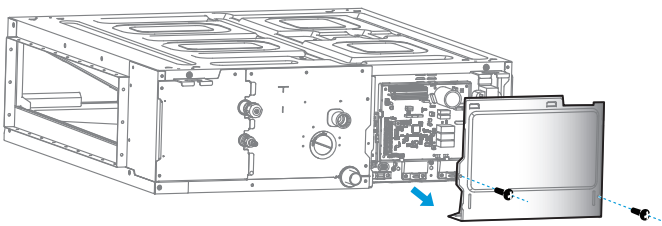

- 2** Remove the pipe clamp board.

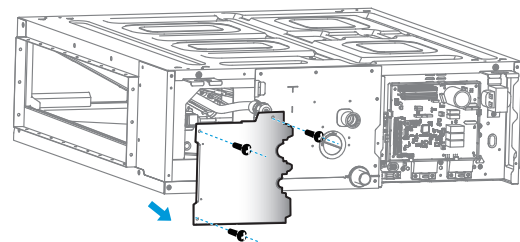

- 3** Remove and repair the drain pump assembly.

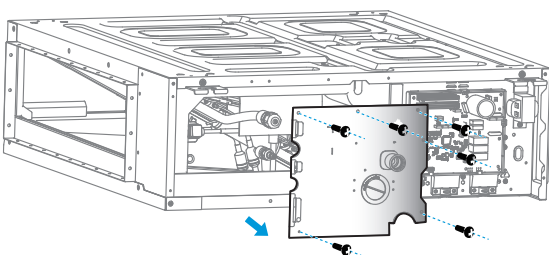

- 4** Replace temperature sensor and electronic expansion valve.

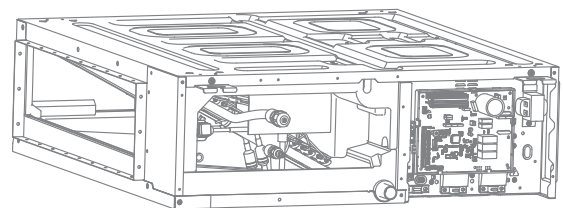

## Maintenance of electronic control board

- 1 Remove the electric control box cover.
- 2 Check the circuit, components and other problems or replace the main control board.
- 3 After replacing the main control board, use the after-sale tool to scan the QR code on the electric control box, and reset the model and horsepower of the unit.

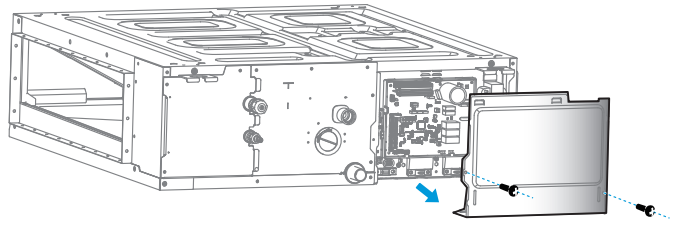

### [ Note ]

The electric control boards of different IDUs are not interchangeable.

## Maintenance of motor shaft and coupling (model with 3 fans)

- 1 Remove the two screws under the return air cover. The following example will refer to the air return model. First, remove the filter if any.

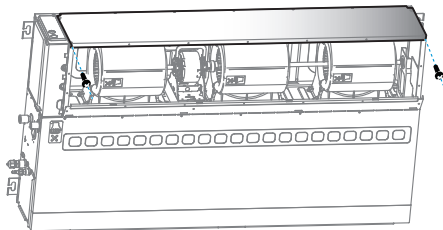

- 2 Refer to the maintenance procedure of propeller housing to remove the lower propeller housing located at the side with a coupling and loosen the fastening screws on the coupling.

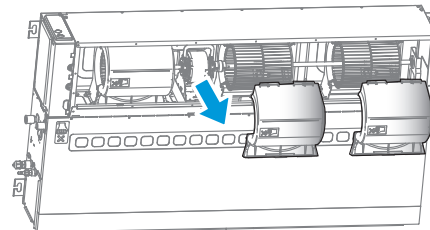

- 3 Push the coupling toward the wind wheel.

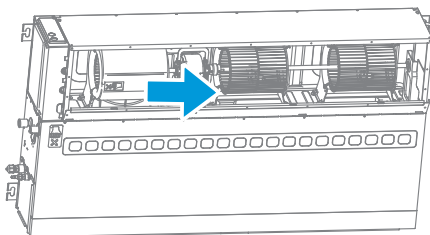

- 4 Remove the wind wheel, connecting shaft and coupling together.

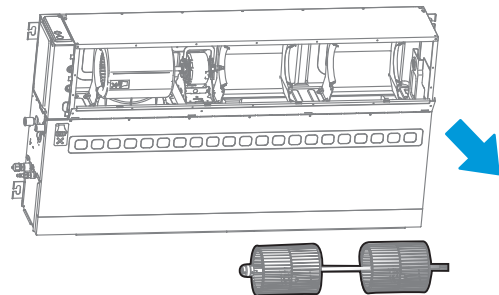

- 5 Loosen the fastening screws for the wind wheel and remove the coupling and motor shaft.

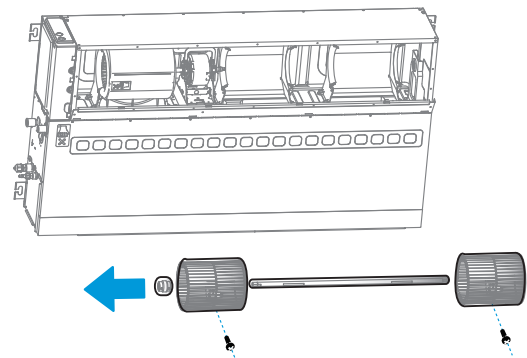

## Maintenance of the bearing block (model with 3 fans)

- 1** Remove the two screws under the return air cover. The following example will refer to the air return model. First, remove the filter if any.

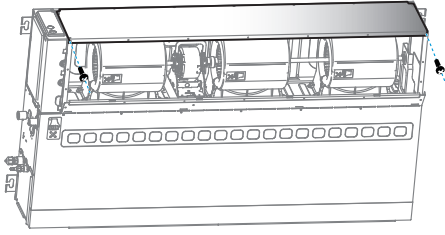

- 2** Refer to the maintenance procedure of the propeller housing to remove the lower propeller housing near the bearing block.

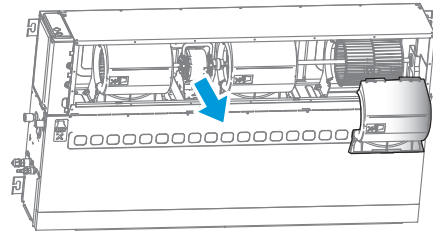

- 3** Use a tool to eject the bearing block to the right and remove it. Or, refer to the disassembly procedure of motor shaft and coupling, first remove the motor shaft, and then remove the bearing block.

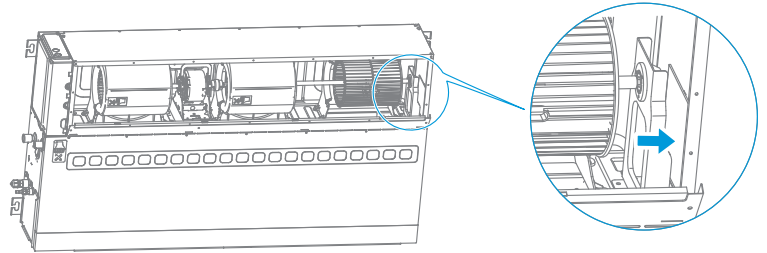

## ErP Information

Fan Types	Centrifugal fan		
Directive (or Standard) for Regulation	ErP Directive 2009/125/EC COMMISSION REGULATION (EU) No 327/2011		
Model Name	ZKSN-240-8-4+LX-175*213*15-41JS	Rev.	
Prepare by			

### Specified Information of Fan:

No.	Information Item	Comment
1	$\eta_{\text{target}} =$	32.5%
2	Overall efficiency ( $\eta_e$ ) =	38.2%
3	Pass or not (Criteria: $\eta_e \geq \eta_{\text{target}}$ )	Pass
4	Measurement category (A-D)	A
5	Efficiency category (static or total)	Static
6	Efficiency grade at optimum energy efficiency point	N =49.7
7	VSD is integrated within the fan	YES
8	Year of Manufacture	Ref. to the Unit Nameplate
9	Manufacturer's name and place of manufacture	Ref. to the Unit Nameplate
10.1	Rated motor power input(s) (kW), at optimum energy efficiency	0.153kW
10.2	Rated motor flow rate(s) at optimum energy efficiency	0.515 m <sup>3</sup> /s
10.3	Rated motor pressure(s) at optimum energy efficiency	113Pa
11	Rotations per minute (R.P.M)at the optimum energy efficiency point	1180r/min
12	Specific ratio	1.001
13	Information relevant for facilitating disassembly, recycling or disposal at end-of-life	all materials can be recycled
14	Information relevant to minimize impact on the environment and ensure optimal life expectancy as regards installation, use and maintenance of the fan	For installation, the clearance of 500 mm shall be kept from inlet
15	Description of additional items used when determining the fan energy efficiency, such as ducts, that are not described in the measurement category and not supplied with the fan.	Measurement category A, fan is free inlet and outlet conditions
16	Motor manufacturer	Jiangsu Shangqi Group Co., Ltd..

## ErP Information

Fan Types	Centrifugal fan		
Directive (or Standard) for Regulation	ErP Directive 2009/125/EC COMMISSION REGULATION (EU) No 327/2011		
Model Name	ZKSN-240-8-3+LX-200*180*15-47JS	Rev.	
Prepare by			

### Specified Information of Fan:

No.	Information Item	Comment
1	$\eta_{\text{target}} =$	32.7%
2	Overall efficiency ( $\eta_e$ ) =	37.8%
3	Pass or not (Criteria: $\eta_e \geq \eta_{\text{target}}$ )	Pass
4	Measurement category (A-D)	A
5	Efficiency category (static or total)	Static
6	Efficiency grade at optimum energy efficiency point	N =49.1
7	VSD is integrated within the fan	YES
8	Year of Manufacture	Ref. to the Unit Nameplate
9	Manufacturer's name and place of manufacture	Ref. to the Unit Nameplate
10.1	Rated motor power input(s) (kW), at optimum energy efficiency	0.162 kW
10.2	Rated motor flow rate(s) at optimum energy efficiency	0.555m <sup>3</sup> /s
10.3	Rated motor pressure(s) at optimum energy efficiency	110Pa
11	Rotations per minute (R.P.M)at the optimum energy efficiency point	1180 r/min
12	Specific ratio	1.001
13	Information relevant for facilitating disassembly, recycling or disposal at end-of-life	all materials can be recycled
14	Information relevant to minimize impact on the environment and ensure optimal life expectancy as regards installation, use and maintenance of the fan	For installation, the clearance of 500 mm shall be kept from inlet
15	Description of additional items used when determining the fan energy efficiency, such as ducts, that are not described in the measurement category and not supplied with the fan.	Measurement category A, fan is free inlet and outlet conditions
16	Motor manufacturer	Guangdong Welling Motor Manufacturing Co., Ltd..

MUNDO  CLIMA®



C/ ROSSELLÓ, 430-432  
08025 BARCELONA  
ESPAÑA / SPAIN  
(+34) 93 446 27 80  
SAT: (+34) 93 652 53 57

[www.mundoclima.com](http://www.mundoclima.com)